

INSTRUCTION MANUAL

M E T E R I N G P U M P S

LINC86 Series Electric Chemical Metering Pump
Plunger Type
Bellows Type



METERING PUMPS

ORDERING & SERVICE

To Order, Call 800.455.LINC

Or FAX your order anytime to
215.293.0498

For the Nearest Authorized

Representative:

By Telephone: **800.455.LINC** for
the US & Canada, **215.293.0465** or
215.441.0800 for International
customers

By Fax: 215.293.0498

E-mail:

LINCORDER@MILTONROY.com

Technical Support

By Telephone: **800.455.LINC** or
215.293.0498

By E-mail:

INFO@LINC PUMPS.com

Convenient Hours

Our phone lines are open Monday
– Friday 8:00 AM – 4:45 PM (EST)

LINC Warranty

Three year limited warranty on all our
products against defects in materials.

LINC Technical Support

Technical service and support
begins with an easy toll-free call.
Many times, our experienced
customer service reps can isolate
and resolve problems over the
phone or provide a referral to our
authorized representatives nation-
wide. We also offer factory repair
services with facilities in Ivyland,
PA. if a warranty issue that cannot
be resolved locally.

Purchase Orders

All mail-in purchase orders must
be signed by an authorized
person. When ordering please list:

- Quantity
- Description of Items
- Shipping Address
- Billing Address
- Purchase Order Number

Request for Quotation – RFQ's

Please send RFQ's to:

By Mail:

Linc Milton Roy
Attn: Customer Service
201 Ivyland Road
Ivyland, PA 18974
USA

By Fax:

1.215.293.0498

By E-mail:

Lincorders@miltonroy.com

Freight Charges

All shipments are F.O.B., Ivyland,
PA, USA. Shipping and handling
are included on the invoice,
prepay and add.

Terms

With credit approval, net 30 days.

METERING PUMPS

T A B L E O F C O N T E N T

Contents - 86 Series Electric Pump Manual	Page
General Specifications (5,000 psi Pumps)	4
Pump Head Selection Chart (5,000 psi Pumps)	4
General Specifications (10,000 psi Pumps)	5
Pump Head Selection Chart (10,000 psi Pumps)	5
Gear Box/Motor Selection Chart	5
Ordering Chart	6
Scope Of This Manual	7
Installation	7
Maintenance	7
Removing the Pump from Service	7
Plunger Type Pump Head Service	7
Replace The Plunger	8
Replace The Power Plunger or Spring	8
Replace The Seals	8
Suction Check Valve	9
Discharge Check Valve	9
Bellows Type Pump Head Service	9
Replace Seals, and Bellows	9
Drive Housing Assembly	10
Remove Bearings From The Cam Shaft	10
Assembly Drawings & Parts Lists	
Figure 1, 86-1,-2,-3 Series Standard Plunger Pump Assembly Drawing	12
Pump Assembly Parts List: 86-1,-2,-3 Standard Series Pumps	13
Figure 2, 86-20,-30 Series Bellows Pump Assembly Drawing	14
Bellows Pump Head Selection Chart	14
Pump Assembly Parts List: 86-20,-30 Bellows Series Pumps	15
Figure 3, 86-1 10,000 psi Pump Assembly Drawing	16
Pump Assembly Parts List: 86-1 10,000 psi Pump	17
Figure 4, 86-4,-6 Series Pump Assembly Drawing/Parts List	18
Figure 5, Discharge Check Valves	19
Figure 6, Suction Check Valves	20
Figure 7, Drive Housing	21
Figure 8, Double Drive Housing	22
Dimensional Drawings	23
LINC Chemical Pump Gas Consumption Chart	24

METERING PUMPS

ELECTRIC PUMP

General Specifications: 86 Series Electric Metering Pumps; 5,000 psi

Parts:

Wetted Parts:	316 Stainless Steel
Pump Body:	303 Stainless Steel
Plunger- Standard:	1/4", 3/8" & 1/2" heads, ceramic 3/4" & 1" heads, 316 ss/ceramic coated
Hydraulic Seal:	Lubritthane (Bellows Head only)
Plunger Seal:	Refer to Ordering Chart

Plunger Sizes:

Bellows Head:	3/8" & 1/2" plunger diameters
Plunger Head:	1/4", 3/8" & 1/2", 3/4" & 1" plunger diameters

Check Valves :

Body:	316 Stainless Steel
Ball:	Carbide
Spring - Discharge:	316 Stainless Steel
Seat:	TFE

Drive Components:

Pump Drive Housing:	Ductile, manufactured to ASTM-A536
Gear Box:	Manufactured to ASTM-A536

Motor Option:

Drip-Proof Enclosure:	Typically used indoor in clean locations.
------------------------------	---

TEFC - Totally Enclosed Fan Cooled:	Typically used in dirty and/or damp locations.
--	--

Explosion Proof:	Listed as explosion proof for Class I, Division 1, Group C & D.
-------------------------	---

Pressure:	To 5,000 psi maximum
------------------	----------------------

Optional Materials:	316 ss, Hastelloy, Monel & Titanium
----------------------------	-------------------------------------

The LINC 86 Series: Pump Head Selection Chart

Model Number	Plunger Diameter	Gear Ratio	Maximum Rate Gal/Hr	Maximum Rate Liter/Hr	Minimum Rate Gal/Hr	Minimum Rate Liter/Hr	Maximum Pressure psi	Maximum Pressure Bar	Strokes Per Minute	Volume Per Stroke	Stroke Length
86-1X1	1/4"	20:1	0.82	3.11	0.08	0.30	5,000	345	86.2	0.6 cc	3/4"
86-1X2	1/4"	30:1	0.54	2.07	0.05	0.18	5,000	345	57.5	0.6 cc	3/4"
86-1X3	1/4"	60:1	0.27	1.03	0.02	0.07	5,000	345	28.7	0.6 cc	3/4"
86-2X1	3/8"	20:1	1.85	7.01	0.18	0.68	4,000	276	86.2	1.3 cc	3/4"
86-2X2	3/8"	30:1	1.23	4.67	0.12	0.45	4,000	276	57.5	1.3 cc	3/4"
86-2X3	3/8"	60:1	0.61	2.33	0.06	0.22	4,000	276	28.7	1.3 cc	3/4"
86-3X1	1/2"	20:1	3.29	12.47	0.32	1.21	3,000	206	86.2	2.4 cc	3/4"
86-3X2	1/2"	30:1	2.19	8.31	0.21	0.79	3,000	206	57.5	2.4 cc	3/4"
86-3X3	1/2"	60:1	1.09	4.16	0.10	0.38	3,000	206	28.7	2.4 cc	3/4"
86-4X1	3/4"	20:1	7.41	28.07	0.74	2.80	1,000	69	86.2	5.4 cc	3/4"
86-4X2	3/4"	30:1	4.94	18.71	0.49	1.85	1,000	69	57.5	5.4 cc	3/4"
86-4X3	3/4"	60:1	2.47	9.36	0.24	0.91	1,000	69	28.7	5.4 cc	3/4"
86-6X1	1"	20:1	13.18	49.92	1.31	4.99	600	41	86.2	9.6 cc	3/4"
86-6X2	1"	30:1	8.79	33.28	0.87	3.29	600	41	57.5	9.6 cc	3/4"
86-6X3	1"	60:1	4.39	16.64	0.43	1.62	600	41	28.7	9.6 cc	3/4"

Notes:

1. Maximum Rate and Minimum Rate columns are for each pump head.
2. Strokes per minutes is based on the use of a 1725 RPM motor.
3. When creating a Model Number using the Ordering Chart, the "X" in the Model Number column above will be replaced by a single digit representing the plunger seal selection. The plunger seal is shown in the Ordering Chart.

METERING PUMPS

ELECTRIC PUMP

General Specifications: 86 Series Electric Metering Pump; 10,000 psi

Parts:

Wetted Parts:	316 Stainless Steel
Pump Body:	303 Stainless Steel
Plunger, Standard:	Ceramic
Plunger Seal:	See Ordering Chart (Options 4 & 6 only)
Plunger Sizes:	1/4" Diameter
Check Valves :	
Body:	316 Stainless Steel
Ball:	Carbide
Spring-Discharge:	316 Stainless Steel
Seat:	TFE

Drive Components:

Pump Drive Housing:	Ductile, manufactured to ASTM-A536
Gear Box:	Manufactured to ASTM-A536
Motor Option:	
Drip-Proof Enclosure:	Typically used indoor in clean locations.
TEFC - Totally Enclosed Fan Cooled:	Typically used in dirty and/or damp locations.
Explosion Proof:	Listed as explosion proof for Class I, Division 1, Group C & D.
Pressure:	To 10,000 psi maximum
Optional Materials:	316 ss, Hastelloy, Monel & Titanium

The LINC 86 Electric Series: Pump Head Selection Chart; 10,000 psi

Model Number	Plunger Diameter	Gear Ratio	Maximum Rate Gal/Hr	Maximum Rate Liter/Hr	Minimum Rate Gal/Hr	Minimum Rate Liter/Hr	Maximum Pressure psi	Maximum Pressure Bar	Strokes Per Minute	Volume Per Stroke	Maximum Stroke Length
86-1X1	1/4"	20:1	0.34	1.29	0.08	0.31	10,000	690	86.2	*0.6 cc	3/4"
86-1X2	1/4"	30:1	0.23	0.86	0.05	0.20	10,000	690	57.5	*0.6 cc	3/4"
86-1X3	1/4"	60:1	0.11	0.43	0.02	0.10	10,000	690	28.7	*0.6 cc	3/4"

Notes:

- *1. Volume per stroke decreases to 0.25 cc per stroke @ 10,000 psi.
2. Strokes per minute is based on the use of a 1725 RPM motor.
3. Maximum Rate and Minimum Rate columns are for each pump head.

Gear Box/Motor Selection Chart

Plunger Diameter:	1/4"	1/4"	1/4"	3/8"	3/8"	3/8"	1/2"	1/2"	1/2"	3/4"	3/4"	3/4"	1"	1"	1"
Gear Ratio:	20:1	30:1	60:1	20:1	30:1	60:1	20:1	30:1	60:1	20:1	30:1	60:1	20:1	30:1	60:1
Pump Heads:	Part Number Code for Gear Box Size and Motor Horsepower														
1	11	11	21	11	11	21	11	11	21	11	11	21	11	11	21
2	11	11	21	11	11	21	11	11	21	11	11	21	11	11	21
3	11	11	21	11	11	21	11	11	21	11	11	21	11	11	21
4	11	11	21	11	11	21	11	11	21	11	11	21	11	11	21
5	11	11	21	12	11	21	12	11	21	11	12	21	11	12	21
6	11	11	21	12	11	21	12	11	21	11	12	21	11	12	21
7	12	11	21	12	11	21	23	22	31	23	22	31	23	22	31
8	12	11	21	12	11	21	23	22	31	23	22	31	23	22	31

METERING PUMPS

ELECTRIC PUMP

Ordering Chart: LINC86 Series Electric Metering Pump

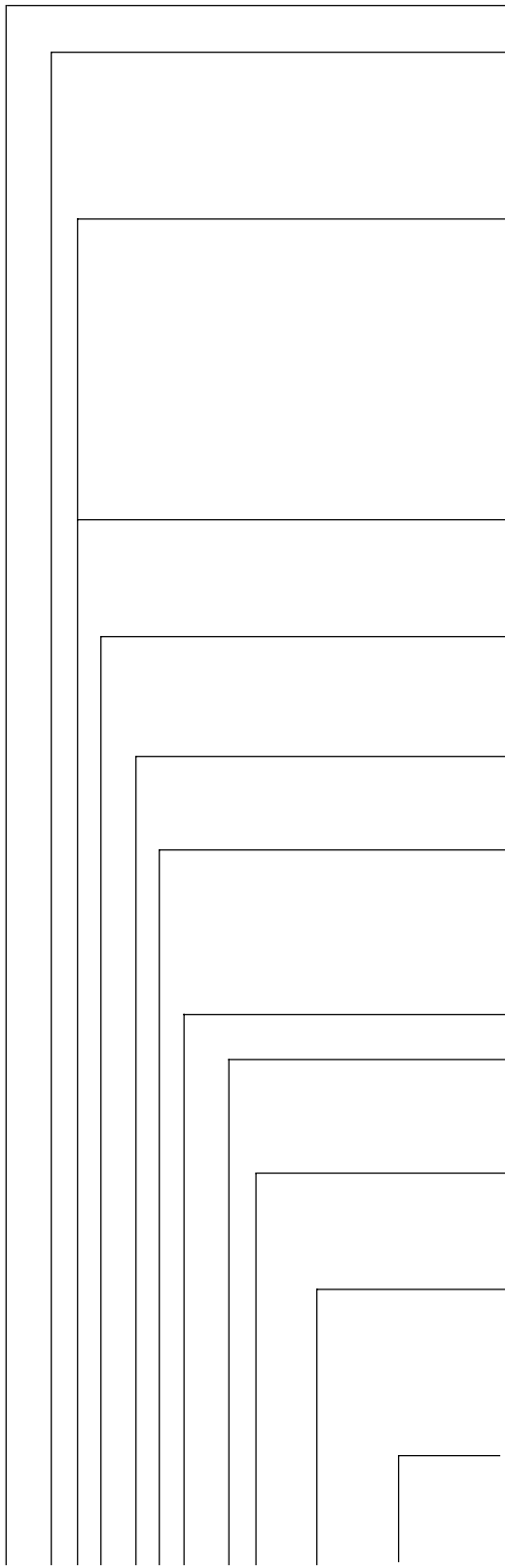

LINC 86- - - - - ()

Example: 86-211-111-11-41 Electric Metering Pump

Series:

86 - Electric plunger and/or bellows type metering pump

Plunger:

- 1 - 1/4" plunger diameter, ceramic
- 2 - 3/8" plunger diameter, ceramic
- 3 - 1/2" plunger diameter, ceramic
- 4 - 3/4" plunger diameter, 316 ss/ceramic coated
- 5 - Multi-Head Pump, specify the plunger sizes required
- 6 - 1" plunger diameter, 316 ss/ceramic coated

Plunger Seal for 1/4", 3/8" & 1/2" Plungers:

- 0 - Packing mechanical seal - Lubrithane, wetted o-rings - TFE, for bellows head only
- 1 - Packing mechanical seal - Fluorocarbon, wetted o-rings - Fluorocarbon
- 2 - Packing mechanical seal - Fluoromyte, wetted o-rings - TFE
- 3 - Packing mechanical seal - Nitrile, wetted o-rings - Nitrile
- 4 - Packing mechanical seal - TFE/Graphite wetted o-rings - TFE
- 6 - Packing mechanical seal - Ultra High Molecular Weight Polyethylene, wetted o-rings - TFE
- 7 - O-rings packing seal - Fluorocarbon, wetted o-rings - Fluorocarbon
- 8 - O-rings packing seal - Nitrile, wetted o-rings - Nitrile
- 9 - O-rings packing seal - Kalrez, wetted o-rings - Kalrez, for 1/4" & 1/2" plungers.

Plunger Seal for 3/4" & 1" Plungers:

- 1 - Packing mechanical seal - TFE/Graphite wetted o-rings - TFE
- 2 - Packing mechanical seal - Ultra High Molecular Weight Polyethylene, wetted o-rings - TFE
- 3 - Packing mechanical seal - Lubrithane, wetted o-rings - TFE

Gear Ratio:

- 1 - 20:1 ratio running at 86.25 RPM
- 2 - 30:1 ratio running at 57.50 RPM
- 3 - 60:1 ratio running at 28.75 RPM
- 4 - No gear box required

Tank:

- 1 - No tank required
- 2 - Plastic tank, 5 U.S. gallon capacity
- 3 - Stainless Steel tank, 5 U.S. gallon capacity

Other:

- 1 - None
- 2 - Bellows head with Lubrithane seal, per head for 3/8" & 1/2"
- 3 - 316 ss wetted parts
- 5 - Specify your requirements
- 6 - Bellows heads - 316 ss wetted parts
- 7 - 10,000 psi maximum working pressure, 1/4" plunger only

Number of Pump Heads:

- 1-8 - Specify the number of heads, one to a maximum of eight

Gear Box Size:

- 0 - None
- 1 - #150
- 2 - #175
- 3 - #200

Motor Horse Power:

- 0 - None
- 1 - 1/3 H.P.
- 2 - 1/2 H.P.
- 3 - 3/4 H.P.

Motor Enclosure Rating:

- 21 - Single phase 110/220 VAC, 60 Hz, TEFC, Standard enclosure
- 31 - Single phase 110/220 VAC, 60 Hz, DP, Drip Proof enclosure
- 41 - Single phase 110/220, 60 Hz, XP, Explosion Proof enclosure
- 23 - Three phase 220/440 VAC, 60 Hz, TEFC, Standard enclosure
- 33 - Three phase 220/440 VAC, 60 Hz, DP, Drip Proof enclosure
- 43 - Three phase 220/440 VAC, 60 Hz, XP, Explosion Proof enclosure

Option Number:

- (x) - If the pump does not require any special modifications, Omit "Option Number" from the part number. If the pump does require special modifications, use "5" for "Other", and "(x)" for the option number when placing an order. The factory will replace the "(x)" with an unique option code at the time of pump production. Example 86-211-151-11-41(6).

METERING PUMPS

E L E C T R I C P U M P

Scope Of This Manual:

This manual describes and provides instructions and parts list for the LINC86 Chemical Metering Pump. These pumps are electrically operated plunger and/or bellows pumps.

Installation:

This manual assumes that the motor that drives this pump has been connected to the power source by a qualified electrician and meets all the required electrical standards of the area where it is installed.

These pumps require a flooded suction and must be located lower than the chemical supply tank. Horizontal installation of the pump head assembly is required.

1. Connect the suction line through a filter or strainer to the suction check valve .
2. Connect the discharge line from the discharge check valve to the desired location.

Note: An inline check valve is recommended at the point of injection to prevent back flow to the pump during shutdown or servicing.

Caution: A pressure relief valve must be installed in the discharge line and set at 10 to 20% above the normal discharge pressure to prevent dead-heading and over pressuring the pump. This pump is capable of producing pressures that will rupture the discharge line. The output of the relief valve should be connected back to the suction line or the chemical supply tank.

3. Prime the pump by loosening the bleed screw (fig. 1, item 24). Allow the liquid (chemical) to flow into the pump chamber, venting the trapped air or gas.
4. Start the pump and run for sufficient time for the pump to discharge continuously and smoothly. Close the bleed screw.
5. After the pump has been operating for a period of time and does not seem to be discharging the proper volume per stroke, loosen the bleed screw slightly until all entrapped air or gas is evacuated from the pump chamber. Tighten the bleed screw.
6. To vary the volume that the pump delivers on each stroke, loosen the set screw (fig. 1 item 4,) and rotate the stroke adjustment collet (fig. 1, item 18). Clockwise rotation will increase the volume and counterclockwise rotation will reduce the volume. The stroke may be adjusted while the pump is running. The edge of the collet aligns with an indicator that shows per centage of full stroke.
7. After the collet has been adjusted so that the pump is delivering the desired volume, tighten the set screw to lock the collet in place.

Maintenance:

Refer to all sectional drawing and parts list in this manual. All repairs should be performed in a clean environment.

The following steps must be taken before proceeding with any maintenance operations.

Removing the Pump from Service:

1. Turn off the electrical power to the pump and make sure it is locked out.
2. Close the upstream and downstream valves on the chemical lines.
3. Open the bleed screw to release the pressure in the pump.
4. Disconnect the suction and discharge lines from the check valves.

Pump Head Assembly

86-1, 86-2, 86-3, 86-4, 86-6;
1/4", 3/8", 1/2", 3/4" & 1" Plungers:

1. The entire pump head assembly may be removed as a unit.
2. Loosen the set screw (fig. 7, item 11) on the boss of the drive housing assembly.
3. Unscrew the pump head assembly by turning the hex mounting adapter (fig. 1, item 19) counterclockwise.

METERING PUMPS

ELECTRIC PUMP

To replace the Plunger:

1. Loosen the four set screws around the head spacer (fig. 1, item 4) closest to the hex mounting adapter (fig. 1, item 19). The pump head may now be removed without removing the packing.
2. Pull the assembly straight out, away from the adapter, being careful not to damage the plunger.
3. Drive out the pin and remove the plunger (fig. 1, items 7 & 8). Replace the new plunger and pin.

To replace the Power Plunger or Spring, fig. 1, items 1 & 2:

1. Remove the retaining ring (fig. 1, item 6).
2. Pull the power plunger out of the mounting adapter and collet assembly (fig. 1, items 19 & 18).
3. Screw the collet off of the mounting and inspect the seal (fig. 1, item 25). Replace any of the parts that are worn or damaged and reassemble.
4. After the parts have been reassembled, compress the spring completely and let it return pulling the retaining ring up against the collet making certain there is no binding.

To replace the Seals:

1/4", 3/8" & 1/2" Only

1. Loosen the four cap screws that attach the end cap to the seal body (fig. 1, items 11, 12 & 16).

2. Separate the seal body from the head spacer by removing the four set screws (fig. 1, item 4) nearest the fluid end of the pump head assembly.
3. Push the old seals, spacer and split bushing out of the seal body (fig. 1, items 23, 22 & 21).

Note: These seals can either be uniseals (seal back-up built into the seal) or seals with separate back-up rings.

4. Lubricate the new seals to prevent damage during installation.
5. Replace the seals by first placing the split bushing into the seal body followed by the spacer and seal (expander ring side facing out toward the fluid end of the pump). If a seal with a backup is being used, the back-up goes in first.
6. Place this assembly over the plunger and reattach to the head spacer with the four set screws.
7. Install a new o-ring (fig. 1, item 15) in the seal body and attach the end cap with the four cap screws.

To Replace the Seals:

3/4" & 1" Only

1. Remove the four screws that attach the end cap to the seal body (fig. 4 item 20). Pull the end cap out of the seal body.

2. Remove the four screws that attach the head spacer to the seal body (fig. 4 item 24). Pull the head spacer away from the seal body.
3. Pull the center ring (fig. 4 item 23) out of the seal body.
4. Remove the plunger seals (one in each end of the seal body) and the seal backup (one per seal if used) from the seal body, being careful not to scratch the wall of the seal gland. The seal spacer (fig. 4 item 13) can remain in the seal body.
5. Before reinstalling the plunger seals, lubricate them and their glands with a light grease. Install the seals with their lips facing the end of the pump that is equipped with check valves. If the seals that are being installed require seal backup rings, install the backup rings behind the heel of the seal.
6. Using the screws that were previously removed, reattach the head spacer and the end cap to the seal body.
7. Lubricate the plunger before reinserting it into the seal body.
8. Remove 1/8" npt lube plug (fig. 4 item 14). Fill with 30wt motor oil or silicone grease. Replace plug.

METERING PUMPS

ELECTRIC PUMP

To replace or repair the Suction and/or Discharge Check Valve:

Two-Piece, fig. 1, items 10 & 13, fig. 2, items 6 & 17, fig. 5 & 6:

Field repair of check valves is not recommended. However, if the checks are to be repaired, the repairs should be done in a clean environment that has the necessary equipment to check the valves for leakage after they are repaired.

The discharge check valve contains a spring to hold the ball against the seat. In the suction check valve, the ball floats freely.

To repair the Check Valves:

1. Separate the two halves for the check valve (fig. 5 & 6, items 1 & 4).
2. Replace the o-rings, ball and spring as required (fig. 5 & 6 items 2, 3, 5 & 6). In the majority of the check valve the seat o-ring will be Teflon (fig. 5 & 6, item 2). This o-ring may be removed, turned around and reused if a new o-ring is not available. During this procedure, extreme care should be exercised. The ball should be "peened" on the Teflon seat to ensure proper sealing (fig. 5 & 6, items 2, 5 & 1).
3. Connect the outlet of the check valve to an air pressure source and apply 10 psig. Place the inlet of the check valve into water or bubble test fluid. If bubbles appear, reset the ball to the

seat o-ring and retest. Increase the air pressure to 100 psig and again check for leaks as above.

4. Ensure that the proper flow direction, as marked on the valve body, is observed when installing or replacing the check valve.
5. Install the repaired check valves into the pump body and tighten securely.

Optional Bellows Pump Head 86-20 & 86-30 3/8" & 1/2" Plungers: (figure 2)

To replace the Seals, Split Bushings & Bellows:

1. Remove the entire bellows pump head assembly from the drive housing assembly as previously described for the standard pump head assembly.
2. Loosen the four set screws (fig. 1, item 4) that mount the bellows seal body to the head spacer (fig. 1, items 16 & 17). Pull the head spacer assembly, with the plunger attached (fig. 1, item 8), out of the bellows seal body. Loosen the six cap screws (fig. 2, item 13) that hold the bellows seal body to the bellows housing (fig. 2, item 8). Separate the seal body and housing.
3. The split bushings, the spacer and seals (fig. 2, items 14, 15 & 16) can be

removed from the bellows seal body by pushing the round shank of a drill bit through the plunger hole in the bellows seal body. Use a 25/64" diameter bit for the 3/8" plunger pump and a 33/64" diameter bit for the 1/2" plunger pump.

Note: Be careful not to scratch the bore that houses the seals.

4. Remove the bellows (fig. 2 item 10) from the bellows housing (fig. 2, item 8). The bellows will be tight in its housing and may be hard to remove. Do not damage the sealing surfaces while removing the bellows.
5. To reassemble the pump, position the bellows housing in the vertical position, possibly in a vise. Start by placing the bellows spring and bellows (fig. 2, item 9 & 10) in the bellows housing. Then, install the bellows retainer and o-rings (fig. 2, items 12, 2, 3, 4, & 5). Lubricate the o-rings before installation.
6. Fill the bellows with 10W-30 or 5W-30 motor oil depending on temperature conditions using the following procedure.
7. Slowly fill the bellows cavity until oil is flush with the top of the bellows. Air will be trapped in the bellows convolutions.

METERING PUMPS

ELECTRIC PUMP

Note: It is important to remove this air. Insert a small wire or similar item into the cavity and gently stir the oil in the convolutions to release any air. If necessary, add additional oil until it is flush with the top of the bellows.

8. Install the split bushings, spacer and seals in the bellows seal body as shown in Figure 2. The lips of both seals should point toward the bellows. Lubricate the parts before installation. Insert the plunger (with the head spacer assembly attached) into the bellows seal body, through the parts that have just been installed.
9. Fill the small cavity between the seal lip that shows in the end of the bellows seal body and the plunger with silicone grease. This will eliminate an air pocket when the pump is fully assembled. Install the plunger (with the seal body assembly and the head spacer assembly attached) into the bellows housing and bellows. Oil will overflow.
10. Install and tighten the six cap screws (fig. 2, item 13). The screws will need to be tightened several times because of the cold flow of the bellows flange.
11. Screw this entire assembly into the drive housing and tighten the set screw that holds it in place.

Drive Housing Assembly:

The shaft bearing and cam bearing in the drive housing assembly (fig. 7, items 5 & 10) are roller bearings which will provide a long, trouble-free life.

If for some reason the bearings are to be replaced,:

1. Remove the pump head assembly or assemblies from the drive housing.
2. Remove the drive housing from the pump base and remove the coupling half from the drive cam shaft (fig. 7, item 7). Remove the eight screws and bearing plate (fig. 7, items 3 & 4) on the shaft side of the drive housing.
3. Remove the cam shaft and bearing mounting plate from the drive housing.
4. Remove the eight cap screws from the bearing mounting on the outside of the drive housing and remove this plate from the drive housing. The bearing in the mounting plates are pressed in and may have to be removed with a bearing puller. The bearing plate that has the opening for the shaft, also has a shaft oil seal (fig. 7, item 8). Inspect this seal and replace if needed.

To remove the Bearing from the Cam Shaft, fig. 7, items 10 & 7:

1. Remove the snap ring (fig. 7, item 9) from one side of the bearing and pull the bearing off of the cam.
2. Replace with a new bearing and snap ring if needed.
3. Scrape the old gaskets from the drive housing and bearing mounting plates. Clean these surfaces with a solvent to remove the old gasket compound.
4. Using a new gasket and a gasket compound (Permatec Form-A-Gasket #2) replace the blind bearing plate with new bearing installed with the eight cap screws. From the other side of the drive housing case, place the other end of the cam shaft with new bearing in place into the inner bearing race.
5. Again, using a new gasket and gasket compound, place the other bearing mounting plate with new bearing and oil seal over the shaft and fasten to the drive housing with the eight cap screws. This mounting plate has an 1/8" socket head pipe plug in it which should be at the very bottom of the assembly when installed.
6. When in operation, the drive housing should always be properly filled with oil. The oil used in the drive housing should be high quality 90W motor oil.

METERING PUMPS

E L E C T R I C P U M P

7. *Replace oil every 4000 hours by draining the case through the drain plug (fig. 7, item 17) and refilling through the oil fill/vent cup (fig. 7, item 14). Fill housing to the level that the oil will run out the 1/8" NPT hole in the back bearing mounting plate when the socket head plug is removed. When full to this point, replace the plug.*

Note: *See Figure 8 for pumps that are equipped with more than two plunger heads.*

METERING PUMPS

E L E C T R I C P U M P

Figure 1, LINC 86-1, -2, -3 Series Plunger Pump Head
(Only on 1/4" head)

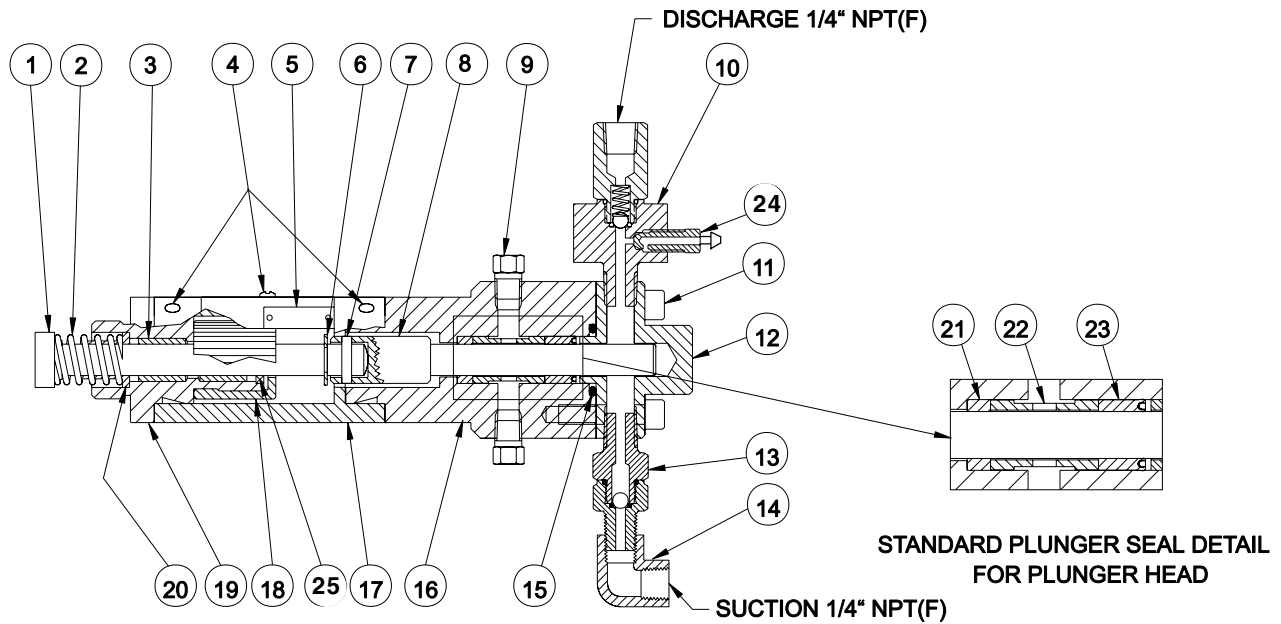

STANDARD PLUNGER HEAD
MODEL 86-1, -2, -3

Standard Head Assembly			Standard Head Assembly		
Size	Part #	Seal Material	Size	Part #	Seal Material
1/4"	45261	UHMWPE	1/4"	45248	TFE/Graphite
3/8"	45263	UHMWPE	3/8"	45250	TFE/Graphite
1/2"	45265	UHMWPE	1/2"	45252	TFE/Graphite

METERING PUMPS

ELECTRIC PUMP

Series 86-1, -2, -3 Plunger Pump Head Parts List; 5,000 psi

Model Plunger Size	86-1 1/4"	86-2 3/8"	86-3 1/2"			
Max Pressure (PSI)	5000	4000	3000			
Item	Part#	Part#	Part#	Description	Material	Qty
1	13174	13174	13174	Power Plunger	17-4 PH ss	1
2	11284	11284	11284	Spring	Chrome/Silicone	1
3	11264	11264	11264	Bushing	Bronze	2
4	11339	11339	11339	Set Screw	18-8 ss	9
5	11470	11470	11470	Stroke Length Plate	302 ss	1
6	11265	11265	11265	Retaining Ring	15-5 PH ss	1
7	13161	13161	13161	Pin	15-5 PH ss	1
8	13168	13169	13170	Plunger	Ceramic	1
9	10278	10278	10278	Lubrication Plug	304 ss	2
10	24940	24940	24940	Discharge Check Valve Assembly	See Parts figure 5	1
11	13159	13159	13159	Cap Screw	18-8 ss	4
12	31632	31636	31640	End Cap	316 ss	1
13	22879	22879	22879	Suction Check Valve Assembly	See Parts figure 6	1
14	13212	13212	13212	Elbow	316 ss	1
15	13197	13198	13199	O-Ring	TFE Encapsulated	1
16	31630	31634	31638	Seal Body	303 ss	1
17	30897	30897	30897	Head Spacer	303 ss	1
18	22833	22833	22833	Collet	303 ss	1
19	30892	30892	30892	Mounting Adapter	303 ss	1
20	25104	25104	25104	Spring Bushing	Acetal	1
21	13163	13164	12990	Split Bushing	PTFE Filled	2
22	24996	24998	25000	Spacer	303 ss	1
23	11821	13188	11822	Plunger Seal	TFE Graphite	1
23a	13007	13154	13008	Plunger Seal	UHMWPE	1
24	20460	20460	20460	Bleed Screw	316 ss	1
25	11259	11259	11259	Seal	Nitrile	1
	22937	22937	22937	Dust Cover (not shown)	Polycarbonate	1
	10324	10324	10324	Drive Screw (not shown)	18-8 ss	4
	13185	13185	13185	Name Plate (not shown)	316 ss	1

METERING PUMPS

ELECTRIC PUMP

Figure 2, LINC 86-20, -30 Series Bellows Pump Head

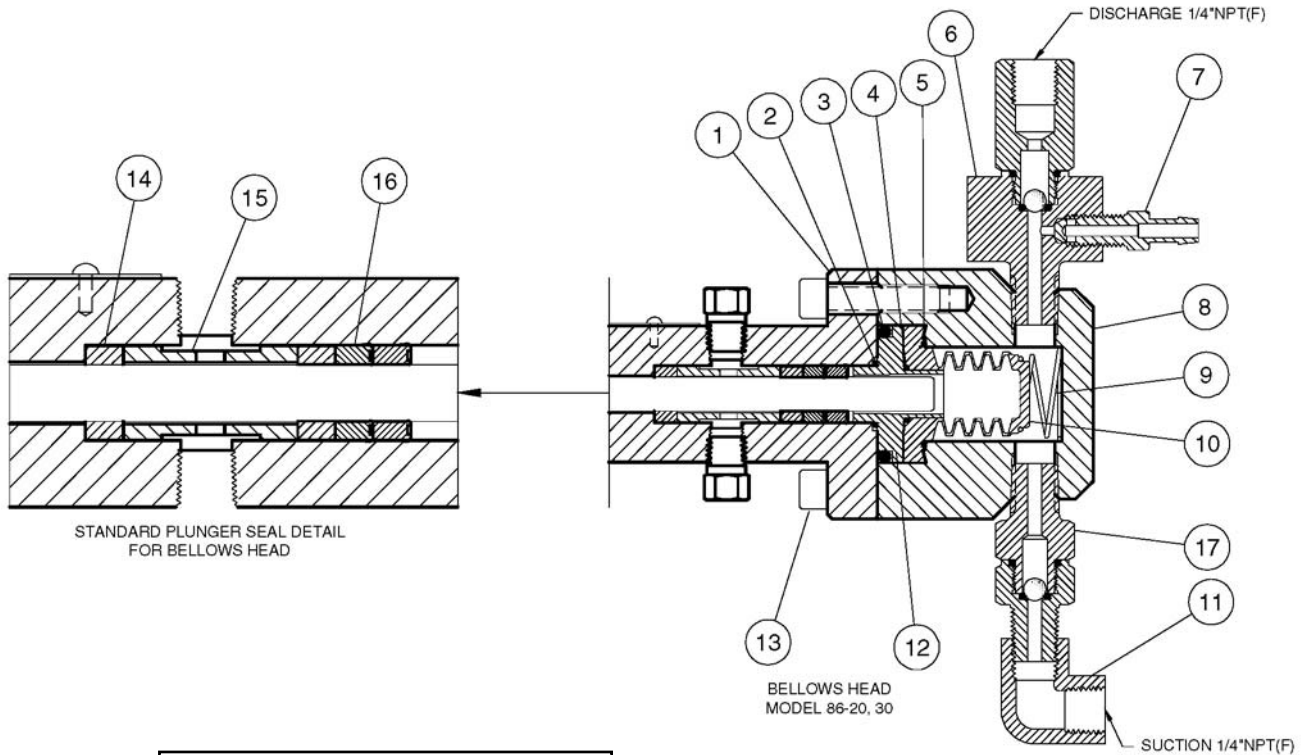

Bellows Head Assembly		
Size	Part #	Seal Material
3/8"	45256	Lubrithane
1/2"	45258	Lubrithane

The LINC 86 Electric Series: Bellows Pump Head Selection Chart; 2400 PSI Max.

Model Number	Plunger Diameter	Gear Ratio	Maximum Rate Gal/Hr	Maximum Rate Liter/Hr	Minimum Rate Gal/Hr	Minimum Rate Liter/Hr	Maximum Pressure psi	Maximum Pressure Bar	Strokes Per Minute	Volume Per Stroke*	Stroke Length
86-201	3/8"	20:1	1.50	5.68	0.18	0.68	2,400	165	86.2	1.1 cc	3/4"
86-202	3/8"	30:1	1.00	3.78	0.12	0.45	2,400	165	57.5	1.1 cc	3/4"
86-203	3/8"	60:1	0.50	1.89	0.06	0.22	2,400	165	28.7	1.1 cc	3/4"
86-301	1/2"	20:1	2.73	10.33	0.32	1.21	2,400	165	86.2	2.0 cc	3/4"
86-302	1/2"	30:1	1.82	6.89	0.21	0.79	2,400	165	57.5	2.0 cc	3/4"
86-303	1/2"	60:1	0.91	3.44	0.10	0.38	2,400	165	28.7	2.0 cc	3/4"

*Volume per stroke shown is maximum available. Actual volume per stroke may decrease by up to 20% at maximum pressure.

METERING PUMPS

ELECTRIC PUMP

Series 86-20, -30 Series Bellows Pump Head Parts List

Assembly P/N Model Plunger Size	45256 86-20 3/8"	45258 86-30 1/2"	Bellows Pump Head		
Item	Part#	Part#	Description	Material	Qty
1	31618	31624	Bellows Seal Body	303 ss	1
2	10311	11546	O-Ring	Fluorocarbon	1
3	13190	10812	O-Ring	Fluorocarbon	1
4	10996	11546	O-Ring	Fluorocarbon	1
5	13353	13354	O-Ring	TFE Encapsulated	1
6	24940	24940	Discharge Check Valve Assembly	See Parts (fig. 5)	1
7	20460	20460	Bleed Screw	316 ss	1
8	31614	31626	Bellows Housing	303 ss	1
9	11541	11542	Bellows Spring	302 ss	1
10	13355	13356	Bellows	TFE	1
11	13212	13212	Elbow	316 ss	1
12	31622	31628	Bellows Retainer	303 ss	1
13	13159		Cap Screw	18-8 ss	6
13		13159	Cap Screw	18-8 ss	8
14	13164	12990	Split Bushing	PTFE Filled	2
15	24998	25000	Spacer	303 ss	1
16	13186	12960	Plunger Seal	Lubrithane	2
17	22879	22879	Suction Check Valve Assembly	See Parts (fig. 6)	1
	10324	10324	Drive Screw (not shown)	18-8 ss	4
	13185	13185	Name Plate (not shown)	316 ss	1

METERING PUMPS

E L E C T R I C P U M P

Figure 3, LINC 86-1 Series Plunger Pump Head; 10,000 psi

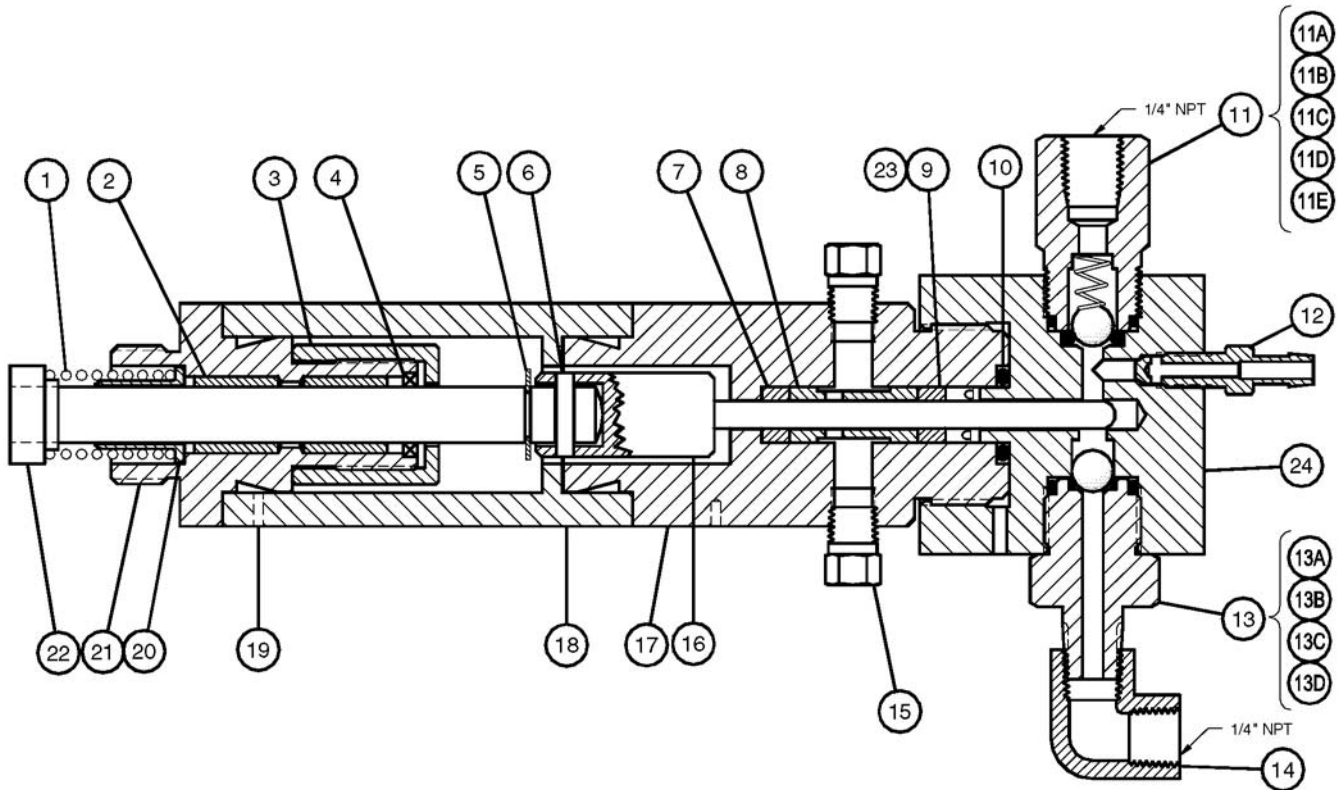

Head Assembly, # 45535

METERING PUMPS

ELECTRIC PUMP

Series 86-1, Series Plunger Pump Head Parts List; 10,000 psi

Assembly P/N	45535	Metering Pump Head; 10,000 psi		
Model	86-1			
Plunger Size	1/4"			
Item	Part #	Description	Material	Qty
1	11284	Spring	Chrome Silicon Steel	1
2	11264	Bushing	Bronze	2
3	22833	Collet	303 ss	1
4	11259	Seal, Power Plunger	Nitrile	1
5	11265	Retaining Ring	15-5 PH ss	1
6	13161	Roll Pin	15-5 PH ss	1
7	13163	Split Bearing	PTFE	1
8	25346	Spacer	303 ss	1
9	11283	Plunger Seal	TFE/Graphite	1
10	13197	O-Ring	TFE Encapsulated	1
11	22626	Discharge Check Valve Assembly	See Parts Below	1
11A	20570	Body, Discharge Check Valve	316 ss	1
11B	10068	Spring	302 ss	1
11C	10283	Ball 3/8"	Carbide	1
11D	10481	O-Ring	TFE	1
11E	10317	O-Ring	TFE	1
12	20460	Bleed Screw	316 ss	1
13	24777	Suction Check Valve Assembly	See parts below	1
13A	10481	O-Ring	TFE	2
13B	10365	O-Ring	TFE	1
13C	10283	Ball, 3/8"	Carbide	1
13D	24790	Body, Suction Check Valve	316 ss	1
14	13212	90° Elbow 1/4" NPT(F) 150#	316 ss	1
15	10278	Lubricant Plug 1/8" NPT	304 ss	2
16	13168	1/4" Plunger	Ceramic	1
17	31723	Seal Body	303 ss	1
18	30897	Head Spacer	303 ss	1
19	11339	Set Screw	18-8 ss	9
20	25104	Spring Bushing	Acetal	1
21	30892	Mounting Adapter	303 ss	1
22	13174	Power Plunger	17-4 PH ss	1
23	22581	Seal Back-Up	Glass Filled Peek	1
24	31721	End Cap	316 ss	1
25	11470	Plate Stroke Length (not shown)	302 ss	1
26	10324	Drive Screw (not shown)	18-8 ss	4
	13185	Nameplate (not shown)	316 ss	1
	22937	Dust Cover (not shown)	Polycarbonate	1

METERING PUMPS

ELECTRIC PUMP

Figure 4, LINC 86-4, -6 Series Plunger Pump Head

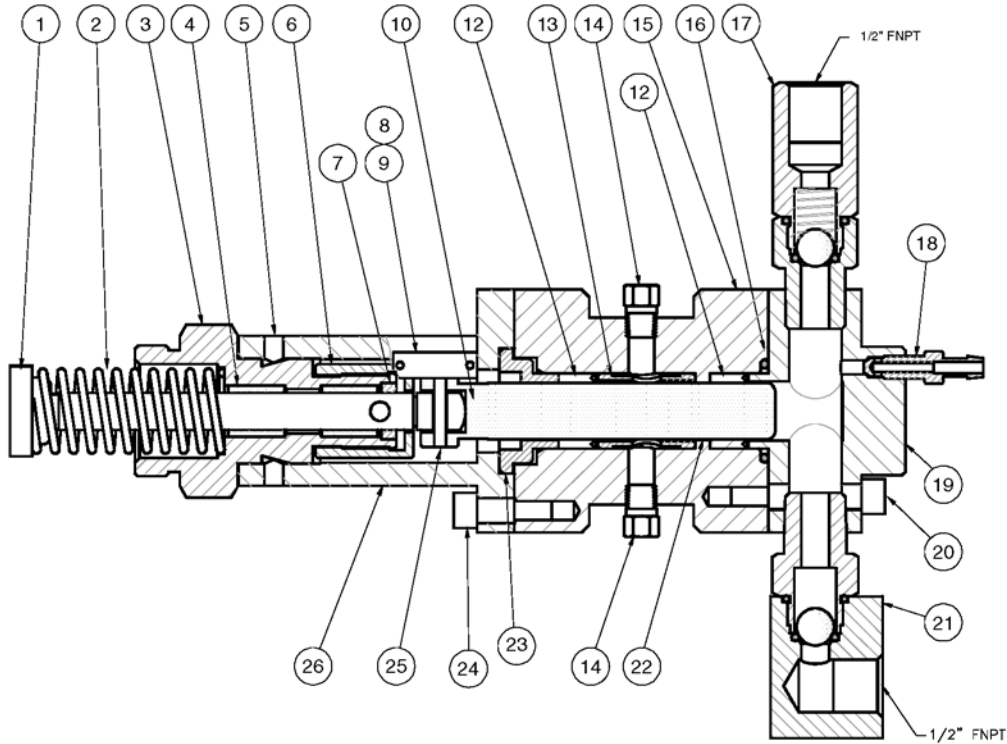

Assembly P/N	45729	45705	Metering Plunger Pump Head		
Model	86-4	86-6			
Plunger Size	3/4"	1"			
Max Pressure PSI	1000	600			
Item	Part #	Part #	Description	Material	Qty
1	25308	25308	Power Plunger	17-4PH	1
2	13316	13316	Spring Plunger	17-4PH	1
3	31782	31782	Mounting Adapter	303ss	1
4	11264	11264	Bushing	Bronze	1
5	11339	11339	Set Screw	18-8ss	7
6	22833	22833	Collet	303ss	1
7	11259	11259	Seal Oil-Lip	Nitrile	1
8	11470	11470	Stroke Length Plate	18-8ss	1
9	10324	10324	Drive Screw	18-8ss	2
10	11265	11265	Retaining Ring	18-8ss	1
11			not used		
12	13379	13344	Seal, High Heel	TFE/Graphite	2
13	25335	25310	Seal Spacer	303ss	1
14	10278	10278	Plug 1/8" NPT	18-8ss	2
15	31796	31784	Seal Body	303ss	1
16	13378	13320	O-Ring TFE/Encapsulated	Viton/TFE	1
17	24842	24842	Discharge Check Valve Assy	316 ss See Parts fig. 5	1
18	20460	20460	Bleed Screw	316ss	1
19	31797	31785	End Cap	316ss	1
20	13195	13195	Screw 5/16-18 x 3/4"	18-8ss	4
21	25423	25423	Suction Check Valve Assy	316 ss See Parts fig. 6	1
22	13340	25311	Plunger	316/Ceramic Coated	1
23	25334	25309	Center Ring	303ss	1
24	13325	13325	Screw 5/16-18 x 1"	18-8ss	4
25	13161	13357	Roll Pin	18-8ss	1
26	31783	31783	Head Spacer	303ss	1
27	13185	13185	Name Plate (not shown)	18-8ss	1
28	22937	22937	Dust Cover (not shown)	Polycarbonate	1

METERING PUMPS

ELECTRIC PUMP

Figure 5, Discharge Check Valves

For 1/4", 3/8" & 1/2"
fig. 1, item 10 or fig. 2 item 6
Part #24940

For 3/4" & 1"
fig. 4, item 17
Part #24842

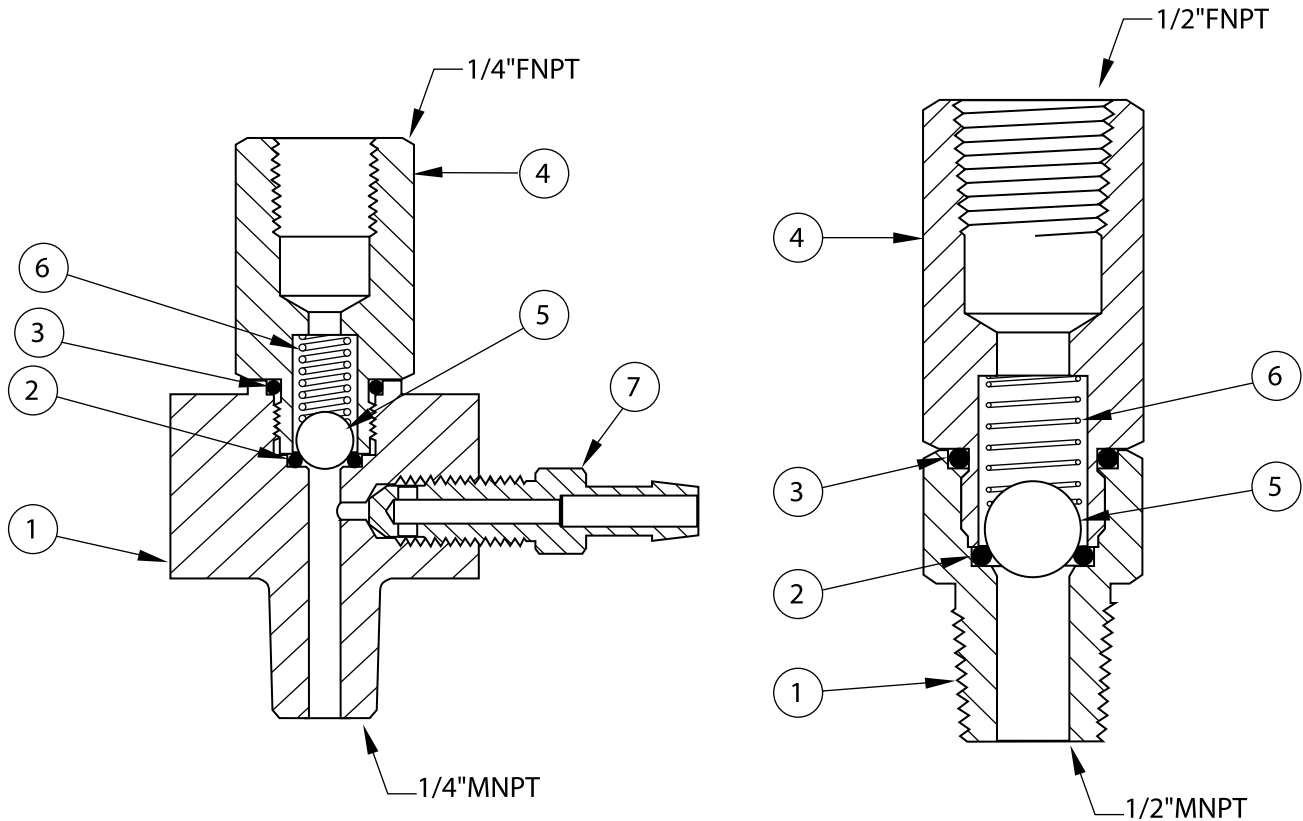

Assembly P/N	24940	24842	Discharge Check Valve - Two Piece Body or Bleed Screw		
Model	86-1, -2, -3	86-4, -6	Description	Material	Qty
Item	Part #	Part #			
1	24939	23569	Inlet Body	316ss	1
2	10313	10469	Seat	TFE	1
3	11485	11595	Seal	Fluorocarbon	1
4	24755	24757	Outlet Body	316ss	1
5	13276	10529	Ball 1/2"	Carbide	1
6	11438	11604	Spring	316ss	1
7	20460		Bleed Screw	316ss	1

METERING PUMPS

E L E C T R I C P U M P

Figure 6, Suction Check Valve

Reference fig. 1, item 13
or fig.2, item 17

Reference fig. 4, item 21

For 1/4", 3/8" & 1/2" Only

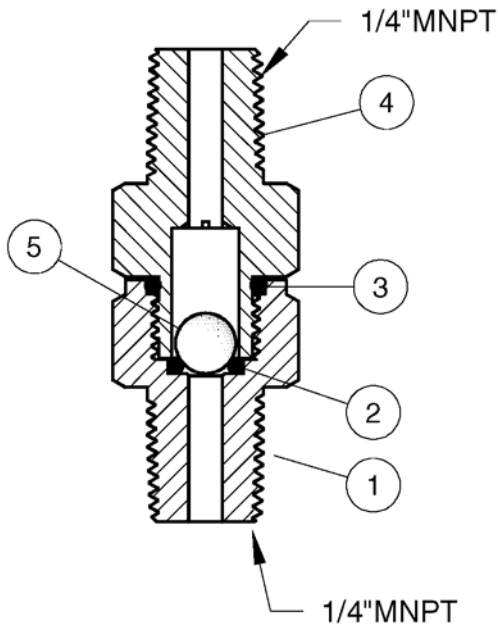

For 3/4" & 1" Only

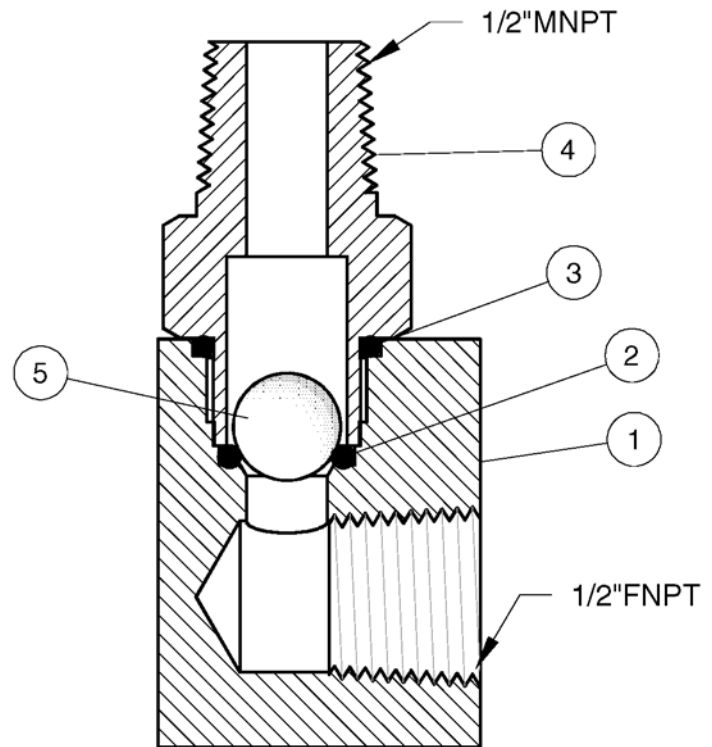

Assembly P/N	22879	25423	Suction Check Valve-Two Piece Body		
Model	86-1,-2, -3	86-4, -6	Description	Material	Qty
Item	Part #	Part #			
1	23257	31786	Inlet Body	316ss	1
2	10313	10469	Seat	TFE	1
3	11485	11595	Seal	Fluorocarbon	1
4	23256	23570	Outlet Body	316ss	1
5	13276	10529	Ball	Carbide	1

METERING PUMPS

E L E C T R I C P U M P

Figure 7, Drive Housing

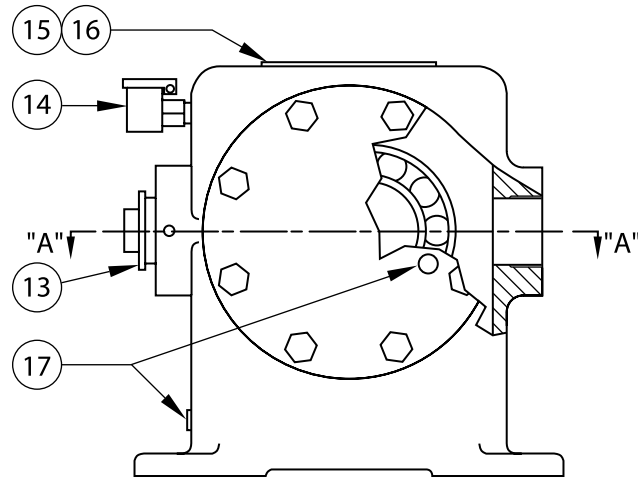

SINGLE DRIVE HOUSING ASSEMBLY

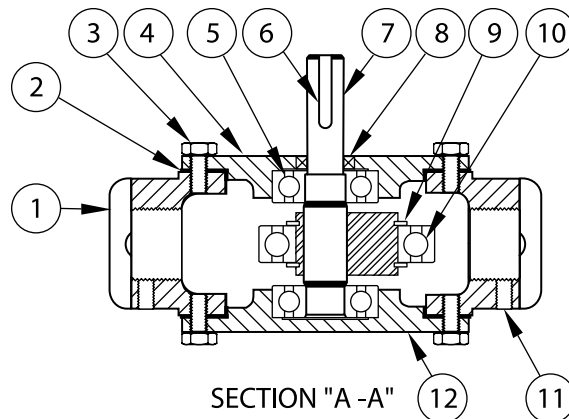

Assembly P/N Model 86	50487 -1, -2, -3 Part #	45708 -4, -6 Part#	Drive Housing Description	Material	Qty
1	50486	45707	Drive Housing	Ductile	1
2	11258	11258	Gasket	Paper	2
3	10205	10205	Cap Screw	Plated	16
4	30899	30899	Bearing Plate (Shaft)	Ductile	1
5	11263	11263	Bearing	Steel	2
6	11262	11262	Key	Steel	1
7	22820	22820	Shaft Assembly	303 ss	1
8	11260	11260	Oil Seal	Nitrile	1
9	11266	11266	Retainer Ring	Steel	2
10	11261	11261	Plunger Bearing	Steel	1
11	11358	11358	Set Screw	18-8 ss	1
12	30898	30898	Bearing Plate (Blind)	Ductile	1
13	25228	25427	Hex Plug	Steel	1
14	11573	11573	Oil Fill/Vent	Plated	1
15	11294	11294	Nameplate	18-8 ss	1
16	10324	10324	Drive Screw	18-8 ss	2
17	10694	10694	Oil Drain Plug	Steel	2
	11329	11329	Coupling (not shown)		1
	11330	11330	Coupling Spider (not shown)		1
	13323	13323	Seal Washer (not shown)	Nitrile	16

METERING PUMPS

E L E C T R I C P U M P

Figure 8, Double Drive Housing

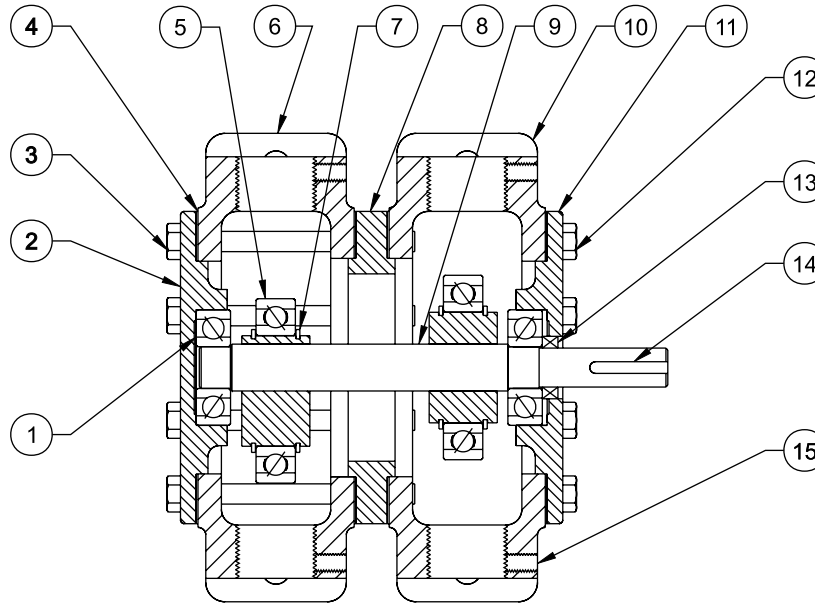

DOUBLE DRIVE HOUSING ASSEMBLY
TOP VIEW

Assembly P/N	50516	45704	Double Drive Housing		
Model # 86	-1, -2, -3	-4, -6			
Item	Part #	Part #	Description	Material	Qty
1	11263	11263	Plunger Bearing	Steel	2
2	30898	30898	Bearing Plate (Blind)	Ductile	1
3	11328	13317	Cap Screw	Plated	8
4	11258	11258	Gasket	Paper	4
5	11261	11261	Bearing	Steel	2
6	50515	45707	Drive Housing	Ductile	1
7	11266	11266	Retainer Ring	Stainless Steel	4
8	30916	31787	Housing Spacer	Steel	1
9	30917	31789	Shaft Assembly	303 ss	1
10	50486	45706	Main Drive Housing	Ductile	1
11	30899	30899	Bearing Plate (Shaft)	Ductile	1
12	10205	10205	Cap Screw	Plated	8
13	11260	11260	Oil Seal	Nitrile	1
14	11262	11262	Key	Steel	1
15	11358	11358	Set Screw	18-8 ss	4
16	10694	10694	Pipe Plug (not shown)	Carbon Steel	3
17	11573	11573	Oil Fill/Vent (not shown)	Plated	2
	11329	11329	Coupling (not shown)		1
	11330	11330	Coupling Spider (not shown)		1
	13323	13323	Seal Washer (not shown)	Nitrile	16

METERING PUMPS

ELECTRIC PUMP

Plunger	1/4"	3/8"	1/2"	3/4"	1"
A	11 1/4" (286 mm)	11 9/16" (295 mm)	11 9/16" (295 mm)	12 3/4" (324 mm)	12 3/4" (324 mm)
B	12 3/8" (314 mm)	12 3/8" (314 mm)	12 3/8" (314 mm)	14 3/16" (360 mm)	14 3/16" (360 mm)
C	7 1/8" (181 mm)	7 1/4" (184 mm)	7 3/8" (187 mm)	8 1/8" (206 mm)	8 1/8" (206 mm)
D	1/4" NPTM	1/4" NPTM	1/4" NPTM	1/2" NPTF	1/2" NPTF
J	3" (76 mm)	3" (76 mm)	3" (76 mm)	3 1/2" (89 mm)	3 1/2" (89 mm)

Gear Box	#150	#175	#200
E	5 1/4" (135 mm)	5 3/8" (140 mm)	5 7/8" (150 mm)
F	3 3/4" (95 mm)	3 7/8" (100 mm)	3 7/8" (100 mm)
G	7 13/16" (198 mm)	7 13/16" (198 mm)	8 1/4" (210 mm)
H	4 7/16" (115 mm)	4 15/16" (125 mm)	5" (130 mm)

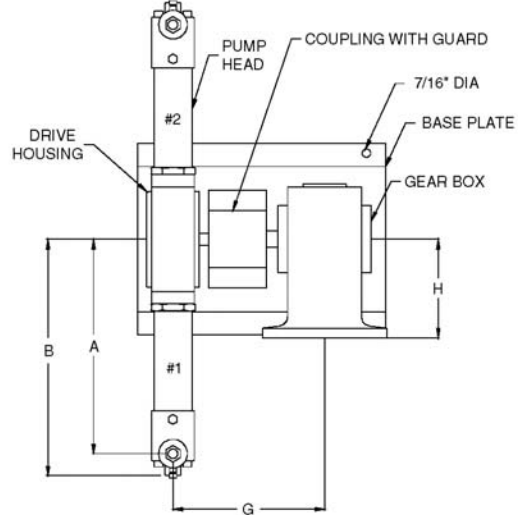

Note: Because of various pump head diameters, not all arrangements shown on this page are available in all pump sizes.

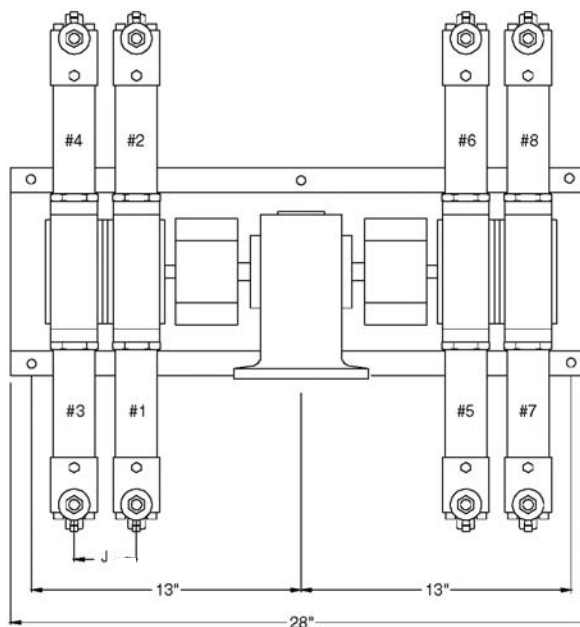
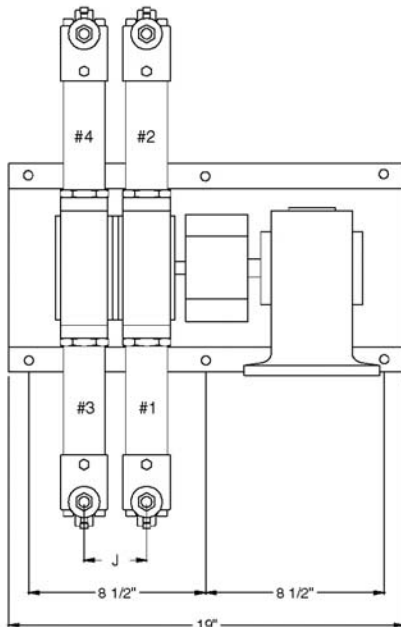
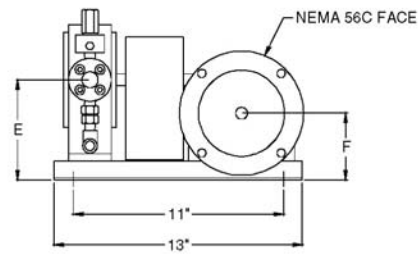
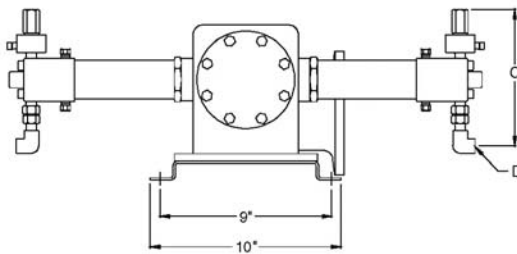



LINC Milton Roy represents and warrants that for a period of 3 years from receipt of the product: (1) the product will be free from defects in materials and workmanship; and (2) the product will perform substantially in accordance with product manuals, literature, or documentation. Any written or oral information or advice given by LINC Milton Roy representatives, agents, or employees will in no way increase the scope of this warranty. If the product fails to comply with the warranty set forth herein, LINC Milton Roy's entire liability and the customer's exclusive remedy will be replacement of the product(s) or, at LINC Milton Roy's option, LINC Milton Roy's reasonable effort to make the product meet the warranty set forth herein. **LINC Milton Roy disclaims all other warranties, either expressed or implied, including but not limited to, implied warranties or merchantability and fitness for a particular purpose, with respect to the product.** This limited warranty gives you specific legal rights. You may have others, which vary from state to state. **These remedies are not available outside of the United States and Canada.** In no event shall LINC Milton Roy or its suppliers be liable for any damages whatsoever (including, without limitation, damages for loss of profits, business interruption, loss of information, or other pecuniary loss) arising out of the use of or inability to use the product, even if LINC Milton Roy has been advised of the possibility of such damages. Information contained in this document is subject to change without notice and does not represent a commitment on the part of LINC Milton Roy. All prices quoted are in U.S. dollars, F.O.B. Ivyland, PA. LINC, LINC Chemical Pumps, and LINC Level & Flow Switches are trademarks of LINC Milton Roy. All other product names and/or registered trademarks are the property of their respective holders. LINC Milton Roy support services are subject to LINC Milton Roy's then-current prices, terms, and conditions, which are subject to change without notice. All prices and specifications, if published, are subject to change without notice.