

# ***INSTRUCTION MANUAL***

**M E T E R I N G P U M P S**

LINC85T-11 & 12 Series Chemical Metering Pump  
Pneumatic Bellows



# M E T E R I N G P U M P S

P N E U M A T I C B E L L O W S

## **To Order, Call 800.455.LINC**

Or FAX your order anytime to  
**215.293.0498**

## **For the Nearest Authorized**

### **Representative:**

By Telephone: **800.455.LINC** for  
the US & Canada, **215.293.0465** or  
**215.441.0800** for International  
customers

By Fax: 215.293.0498

E-mail:

LINCORDER@MILTONROY.com

## **Technical Support**

By Telephone: **800.455.LINC** or  
**215.293.0498**

By E-mail:

INFO@LINCUMPS.com

## **Convenient Hours**

Our phone lines are open Monday  
– Friday 8:00 AM – 4:45 PM (EST)

## **LINC Warranty**

Three year limited warranty on all our  
products against defects in materials.

## **LINC Technical Support**

Technical service and support  
begins with an easy toll-free call.  
Many times, our experienced  
customer service reps can isolate  
and resolve problems over the  
phone or provide a referral to our  
authorized representatives nation-  
wide. We also offer factory repair  
services with facilities in Ivyland,  
PA. if a warranty issue that cannot  
be resolved locally.

## **Purchase Orders**

All mail-in purchase orders must  
be signed by an authorized  
person. When ordering please list:

- Quantity
- Description of Items
- Shipping Address
- Billing Address
- Purchase Order Number

## **Request for Quotation – RFQ's**

### **Please send RFQ's to:**

By Mail:

Linc Milton Roy  
Attn: Customer Service  
201 Ivyland Road  
Ivyland, PA 18974  
USA

By Fax:

1.215.293.0498

By E-mail:

Lincorders@miltonroy.com

## **Freight Charges**

All shipments are F.O.B., Ivyland,  
PA, USA. Shipping and handling  
are included on the invoice,  
prepay and add.

## **Terms**

With credit approval, net 30 days.

# M E T E R I N G P U M P S

## P N E U M A T I C B E L L O W S

<b>Contents – 85T-11, 12 Pump Manual .....</b>	<b>Page</b>
General Specifications .....	4
Selection Chart .....	4
Ordering Chart .....	4
Scope Of This Manual .....	5
Installation .....	5
Maintenance .....	5
Removing the Pump from Service .....	5
Timer .....	5
Check Valves .....	6
Piston Plunger Assembly .....	6
Plunger Seals .....	7
Bellows Assembly Replacement .....	7
Oil Re-fill/Top-off .....	8
Seal Lubrication .....	8
How To Determine Supply Pressure .....	9
<b>Assembly Drawings &amp; Parts Lists</b>	
Figure 1, 85T-11 & 12 Assembly Drawing .....	10
Pump Assembly Parts List: 85T-11 & 12 .....	11
Figure 2, “T” Series Timer Assembly Drawing .....	12
“T” Series Timer Parts List .....	12
Figure 3, Discharge Check Valve Assembly Drawing .....	13
Discharge Check Valve Parts List .....	13
Figure 4, Suction Check Valve Assembly Drawing .....	13
Suction Check Valve Parts List .....	13
LINC Chemical Pump Gas Consumption Chart .....	14

# METERING PUMPS

## P N E U M A T I C B E L L O W S

General Specifications: 85T Series Pneumatic Bellows Metering Pumps			
<b>Wetted Parts:</b>		<b>Pneumatic Section:</b>	
Pump Body:	303 Stainless Steel	Piston Housing:	303 Stainless Steel
Plunger:	Ceramic	Timer:	303 Stainless Steel
Plunger Seal:	Lubrithane	<b>Plunger Sizes:</b>	1/4" & 1/2" plunger diameters
Bellows:	TFE	<b>Pressure:</b>	To 2,400 psi, maximum
<b>Check Valves :</b>		<b>Optional Materials:</b> Hastelloy, Monel, & Titanium	
Body:	316 Stainless Steel		
Ball:	Carbide		
Spring - Discharge:	316 Stainless Steel		
Seat:	TFE		

The LINC 85T Series: Pneumatic, Bellows-Type Metering Pump Selection Chart												
Model Number	Plunger Diameter	Piston Diameter	Maximum Rate Gal/Hr	Maximum Rate Liter/Hr	Minimum Rate Gal/Hr	Minimum Rate Liter/Hr	Maximum Pressure psi	Maximum Pressure bar	Theoretical Amp. Ratio	Strokes Per Minute	Volume Per Stroke	Stroke Length
85T-11	1/4"	2 1/4"	0.42	1.59	0.006	0.023	2,400 <sup>5</sup>	165.5	81:1	4 - 50	0.53 cc	1"
85T-12	1/2"	3"	1.66	6.28	0.025	0.095	2,400 <sup>5</sup>	165.5	36:1	4 - 50	2.10 cc	1"

**Notes:**

1. Maximum rates are based on 50 strokes per minute.
2. Minimum rates are calculated on: 1/4" and 1/2" pumps are 1/4" stroke length and a minimum of 4 strokes per minute.
3. The timer supply pressure is 15 to 100 psi.\*
4. TFE wetted O-rings are standard.
5. 85T-11 Maximum pressure based on 80 psi supply pressure.\*
6. 85T-12 Maximum pressure based on 100 psi supply pressure.\*

\*Actual pump discharge pressure and stroke frequency will be dependent on the actual timer supply pressure used to stroke the pump.

### Ordering Chart: 85T Series Pneumatic Bellows Plunger Metering Pump

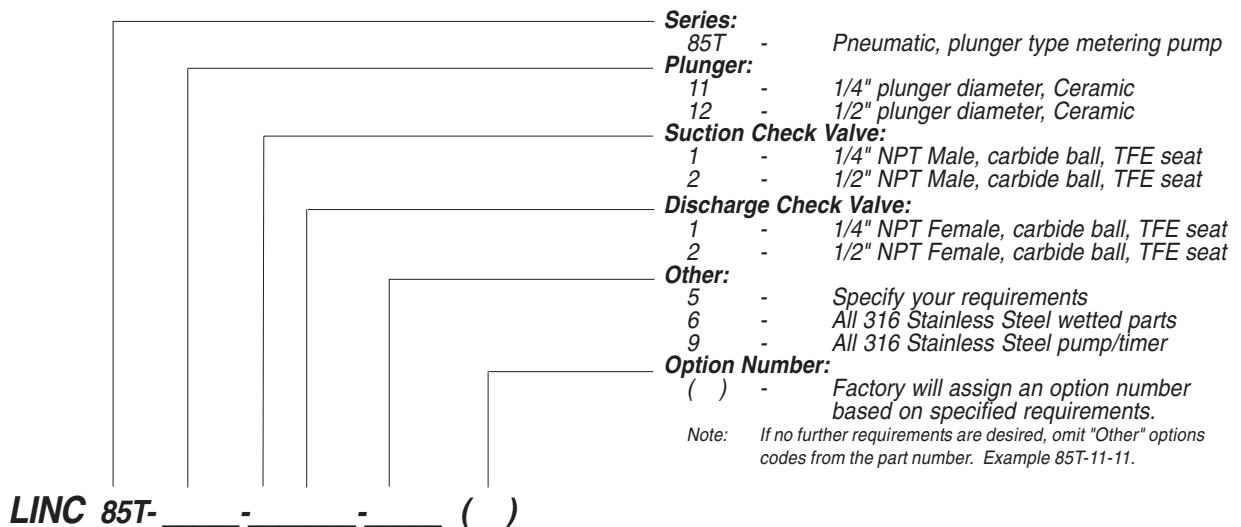

**Example: LINC 85T-12-22-6 Pneumatic, Bellows Metering Pump**

# METERING PUMPS

P N E U M A T I C B E L L O W S

## Scope Of This Manual:

This manual describes the LINC85T Chemical Metering Pump, which is a pneumatically operated bellows type pump. This bellows design isolates the process chemical from the rest of the system.

## Installation:

The LINC85T pump requires a flooded suction and must be installed lower than the chemical supply tank. Vertical installation is required.

1. Connect the suction line to the suction check valve (fig. 1, item 21).
2. Connect the discharge line to the discharge check valve (fig. 1, item 18).

**Note:** Installation of an in-line check valve P/N 25019 at the point of injection is recommended to prevent back flow to the pump during shutdown or servicing.

3. Connect the air or gas supply line to the timer port marked "IN" (fig. 1, item 1).
4. The supply pressure to the timer must be regulated between 15 and 100 psig.\*

\* Actual pump discharge and stroke frequency will be dependant on the actual timer supply pressure used to stroke the pump.

5. Set the regulator output pressure to overcome the discharge pressure. Refer to the paragraph on "Amplification Ratio" at the end of this manual for information on determining the correct supply pressure.
6. To prime the pump, loosen the bleed screw to vent the trapped air allowing the liquid to flow into the pump chamber and out of the bleed plug. Snug tighten the bleed plug (fig. 1, item 22).
7. Start the pump and run for a minimum of 30 seconds. Then, open the bleed plug again to evacuate all remaining air from the pump chamber.

## Maintenance:

Before proceeding with any maintenance procedures, please refer to the sectional drawings in this manual.

## Removing the Pump from

### Service:

1. Rotate the control knob on the timer to the "0" position.
2. Disconnect the supply pressure from the timer.
3. Close the upstream and the downstream valves on the chemical lines.
4. Open the bleed plug to release the pressure.

5. Disconnect the suction and discharge lines from the check valves.

## Timer, Fig. 1, Item 1 & Fig. 2

1. Disconnect the supply pressure from the timer.
2. Rotate the timer counter-clockwise on the pipe nipple that connects it to the piston housing until the timer is vertical with the supply pressure port pointing down.
3. Loosen and remove the two screws from the timer (fig. 2, item 1).
4. Separate the three timer sections and discard the seal, diaphragm and the disc (fig. 2, items 4, 6 & 15). Be careful not to lose the small disc spring (fig. 2, item 16). Note the orientation of the diaphragm as it is removed.
5. Loosen the set screw on the knob (fig. 2, item 11). Remove the knob and knob spring (fig. 2, item 9).
6. Unscrew the adjustment screw (fig. 2, item 10) from the front body (fig. 2, item 13). Remove and discard the o-ring (fig. 2, item 12).
7. Reassemble the timer in reverse order of the above steps, using new rubber parts. Lubricate the adjustment screw threads and its o-ring. No other lubrication is required.

# METERING PUMPS

## PNEUMATIC BELLOW

8. After installing the adjustment screw, turn it in by hand without the knob installed until it lightly seats. During this operations do not over-tighten the adjustment screw into its seat. Apply supply pressure to the timer and unscrew the adjustment screw slowly until the pump starts to run. Trial and error will be necessary to determine the proper orientation of the knob on the adjustment screw. Once the proper orientation is determined, reinstall the knob spring and knob.

### Check Valves, Fig. 1, Item 18 & 21

**Note:** Field repair is not recommended because of potential contamination. These assemblies should be replaced in the field, then serviced in the shop. The check valves feature a two-piece construction for easy repair.

1. Separate the two halves of the check valve (fig. 3 & 4, items 1 & 4).
2. Replace the o-rings, the ball, and spring as required (fig. 3 & 4, items 2, 3, 5, & 6). The Teflon o-ring may be removed, turned around, and reused once, if a new o-ring is not available. During this procedure, extreme care

should be exercised. The ball should be "peened" on to the Teflon seat to ensure proper sealing (fig. 3 & 4, items 5 & 2).

3. Ensure that the proper flow direction, as marked on the check valve body, is observed when installing or replacing the check valves.

### Piston Plunger Assembly, Fig. 1, Item 7, 8, 9, 13, & 14

It is recommended that the pump be repaired in a clean environment. If the pump must be serviced in the field, please use extreme care in handling the parts.

1. Secure the bellows housing in a vise to facilitate disassembly of the pump.
2. Open the bleed plug (fig. 1, item 22) to release any of pressure trapped in the pump cavity.
3. Loosen the Stroke Adjustment Lock Nut, and unscrew the Stroke Adjustment Screw, until all spring tension is removed from the adjusting screw. (fig 1, item 5 & 6)
4. Remove the button head screws, (fig. 1, item 12) while holding the piston housing (fig. 1, item 10) down against the pump. The piston return spring (fig. 1, item 9) will exert an upward force on the piston housing. Carefully remove the piston housing.

5. Carefully remove the exposed piston assembly (fig. 1, item 7) by pulling upwards slowly. Use care not to scratch, or damage, the plunger.
6. Inspect the lower section of the plunger for wear. If scoring is present on this area, replace the piston assembly.
7. Inspect the u-cup seal on the piston and replace if necessary (fig. 1, item 8).
8. Remove the spring, the lubricant seal retainer, and lubricant seal (fig. 1, items 9, 13 & 14), from the spring cavity and discard the old lubricant seal.
9. Place a new lubricant seal, lubricant seal retainer, and spring into the center housing (fig. 1, items 14, 13 & 9).
10. Carefully insert the plunger back into the center housing.
11. Inspect and clean the inside of the piston housing (fig. 1, item 10).
12. Apply a generous amount of light weight lubricant (grease) to the piston u-cup seal (fig. 1, item 8), and to the inside of the piston housing (fig. 1, item 10).
13. Replace the piston housing on the pump and secure with the three button head screws (fig. 1, item 12).



# METERING PUMPS

P N E U M A T I C B E L L O W S

## **Plunger Seals, Figure 1:**

1. Disconnect the air supply from the timer.
2. Open the bleed plug (fig. 1, item 22) to release any pressure trapped in the pump cavity.
3. Remove the four set screws (fig. 1, item 27) from the center section of the pump housing .
4. Remove the top half of the pump by slowly pulling upward. Use care not to damage the exposed end of the plunger.
5. Remove both of the plunger seals (fig. 1, item 24) from the cavity in the lower portion of the pump. Do not use a screw driver or metal tool to remove the seal. Use a paper clip modified to resemble a hook. Insert the hook through the center hole and pull upwards, pulling both seals at the same time.
6. Install one new plunger seal with the u-shaped angle facing down on both seals. Install the first seal at an angle to accommodate installation. Using the upper plunger seal, with the u-shaped angle facing down, position it on top of the first plunger seal and push both seals into position.
7. Both the first and upper plunger seals should fit flush within the packing gland.

8. Check the hydraulic fluid level before continuing. If the fluid level is below the height of the upper seal, then the hydraulic fluid should be refilled. Refer to the "Oil Re-Fill/Top-Off Procedure".
9. Before reassembling the pump, apply a thin coat of silicone grease to the pump plunger.
10. Before installing the center housing (fig. 1, item 28) onto the bellows housing (fig. 1, item 17) the pump must be refilled with oil. Refer to the "Oil Re-Fill/Top-Off Procedure".
11. Reassemble the two pump halves and fasten with the four set screws (fig. 1, item 27).

## **Bellows Assembly Replacement Procedure, Fig. 1, items 19 & 29**

**Note:** It is recommended that the bellows be replaced in a clean environment, if possible.

1. Disconnect the supply pressure from the timer.
2. Close the upstream and downstream valves on the chemical lines.
3. Open the bleed plug to release any pressure trapped in the pump cavity (fig. 1, item 22).
4. Remove the five cap screws and lock washers (fig. 1, items 25 & 26) from the bellows housing.

**NOTE:** The 1/2" Pump 85T-12 has 8 set screw & lock washers.

5. Remove the complete upper section of the pump by pulling upward.
6. Carefully remove the bellows assembly (fig. 1, item 19) from the inside of the housing (fig. 1, item 17). Due to the pressure exerted on the bellows, it may not come out easily. It may be necessary to remove the suction check valve. Push the bellows assembly out from the suction check valve port.
7. Prefill the bellows assembly with oil prior to assembling it into the pump body. 1st fill the bellows with oil, and place it on a level well supported work surface. Place your thumbs on the flanged edge of the bellows, and slightly compress the bellows forcing the trapped air out of the bellows assembly. Refill the bellows with oil and repeat this process until no more bubbles appear in the oil. (This will typically take 2-3 cycles.)

**Note:** The recommended fill fluid for the bellows is 10W-30 or 5W-30 motor oil depending on temperature conditions.

8. Ensure that the bellows

# METERING PUMPS

P N E U M A T I C B E L L O W S

- return spring (fig. 1, item 20) is centered in the housing, the large end of the spring should be down. Assure that the o-ring which is part of the bellows assembly is properly in place in the groove on the lower face of the bellows flange, and that the upper bellow o-ring is in place as well. (fig. 1, item 23 & 29) Replace the new bellows into the housing and gently press until the bellows seats.
9. Replace the upper section of the pump and secure with the cap screws, and washers. (fig. 1, items 25 & 26)
  10. Torque the bolts evenly in a cross pattern to 60 in/lb.
  11. **Warning:** Do not overtighten the mounting bolts. When properly installed, there will be a gap between the bellows adapter and the bellows housing (fig. 1, items 16 & 17).

## **Oil Re-fill/Top-off Procedure, Figure 1:**

**Note:** The recommended fill fluid for the bellows is 10W-30 or 5W-30 motor oil depending on temperature conditions.

1. Disconnect the supply pressure from the timer.
2. Open the bleed plug to release any pressure trapped in the pump cavity (fig. 1, item 22).
3. Remove the four set screws (fig. 1, item 27) on the center section of the pump and remove the top section of the pump.
4. Slowly fill the bellows cavity by adding oil through the center of the plunger seal. Fill the cavity until the oil is flush with the top of the upper plunger seal (fig. 1, item 24).
5. It is important to remove air bubbles trapped within the bellows cavity. Insert a small wire or similar item into the cavity and gently stir the oil in order to release any trapped air. If necessary, add additional oil until it is flush with the top of the upper plunger seal, and the top of the bellows adapter (fig. 1, item 16). For several days this excess oil will slowly bleed out onto the top of the bellows housing. This is normal and does not require a refill.

## **Seal Lubrication:**

1. Remove the pipe plug from the center housing of the pump (fig. 1, item 15).
2. Add silicone base grease (Dow Corning DC-7, part #10354) to the pump.
3. Replace the plug and tighten sufficiently to prevent loosening during operation.
4. Silicone grease should be added approximately every 4-6 weeks depending upon operating conditions.

**Note:** The use of a grease gun is not recommended due to the high pressure that can develop.



# METERING PUMPS

P N E U M A T I C B E L L O W S

## **IMPORTANT: How To Determine Supply Pressure:**

*For best results and longer pump life, it is recommended that a pressure regulator be used upstream of the pump in order to properly adjust the supply pressure. The supply pressure to the pump should be a minimum of 15 psig and a maximum of 100 psig.*

*The "theoretical" amplification ratio of the 85T-11 bellows pump is 81:1. The "theoretical" amplification ratio of the 85T-12 bellows pump is 36:1; however in actual application many factors (ie: Stroke Rate, Fluid Viscosity, Gas Quality, Temperature, etc.) will affect the specific supply pressure required to achieve the desired discharge requirements. Proper balancing of air or gas supply pressure against the discharge requirements will provide longer pump life and reduce maintenance; therefore we recommend that you perform test at your specific conditions to determine what supply pressure will be required to provide the chemical injection rate and pressure, that you desire. Set the supply pressure only marginally (5 psi) above the actual required pressure to obtain the pump performance desired.*

**Note: The discharge pressure of the 85T-11 and the 85T-12 should never exceed 2,400 psig.**

# METERING PUMPS

P N E U M A T I C B E L L O W S

Figure 1, LINC85T-11 & 12 Metering Pump

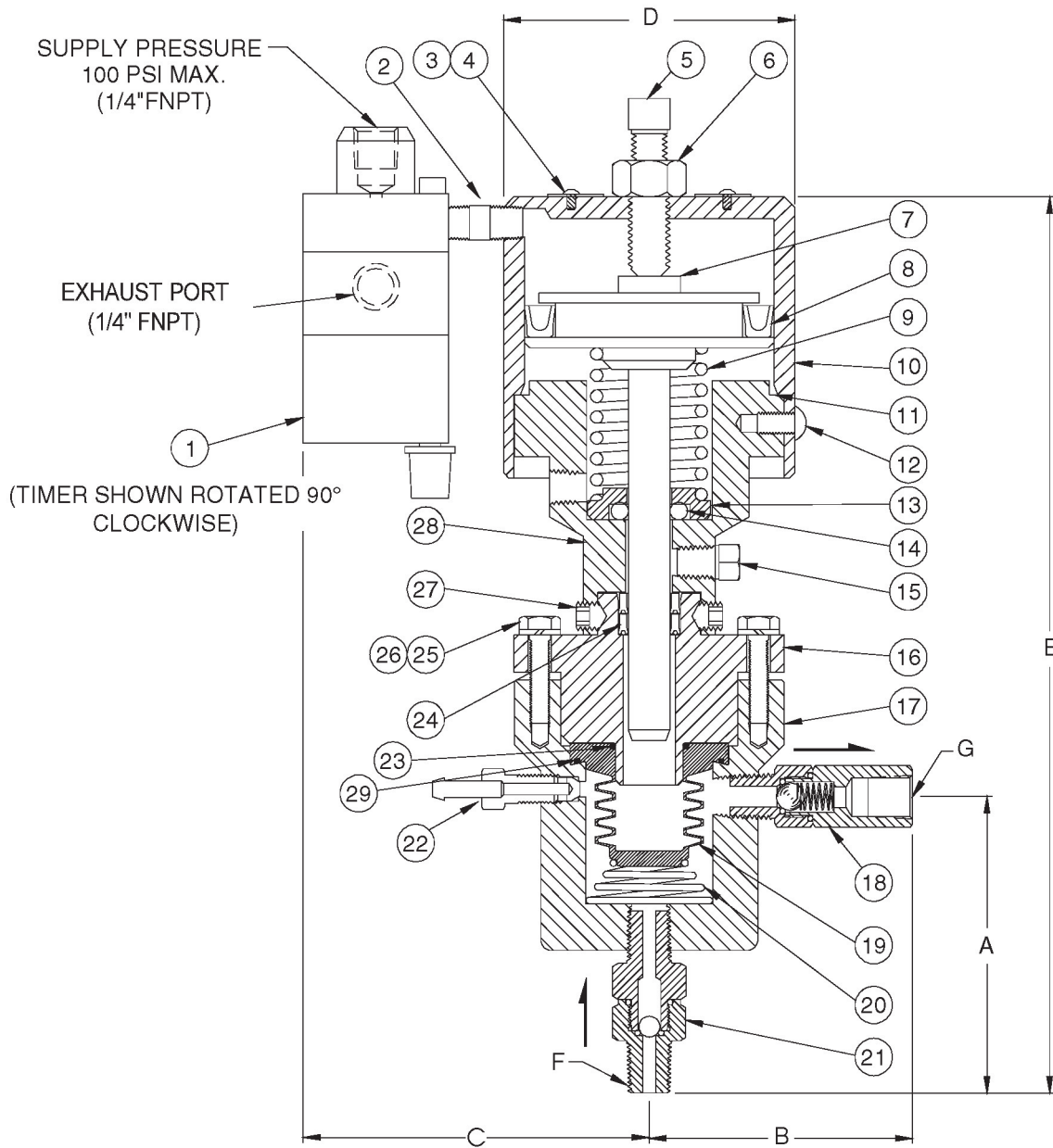

MODEL 85T-12-11

Model	85T-11-11	85T-12-11
A .....	3 1/2"	3 5/8"
B .....	3 1/8"	3 5/16"
C .....	3 7/8"	4 1/4"
D .....	2 3/4"	3 1/2"
E .....	10 3/4"	11"
F Suction .....	1/4" NPTM	1/4" NPTM
G Discharge .....	1/4" NPTF	1/4" NPTF

# METERING PUMPS

P N E U M A T I C B E L L O W S

## LINC85T Metering Pump Parts List

### 85T Pump Assembly

Model	85T-11-11	85T-12-11
Plunger Size	1/4"	1/2"
Piston Size	2 1/4"	3"

Item	Part#	Part#	Description	Material	Qty
1	31668	31668	Pneumatic Timer	See Parts	1
2	25130	25130	Nipple	303 ss	1
3	11243	11243	Name Plate	18-8 ss	1
4	10324	10324	Drive Screw	18-8 ss	2
5	11843	11843	Stroke Adjustment Screw	18-8 ss	1
6	20985	20985	Lock Nut	303 ss	1
7	24647	24670	Piston Assembly	Ceramic	1
8	10019	11146	Piston U-Cup	Nitrile	1
9	10448	12992	Piston Return Spring	17-7 ss	1
10	20457	30744	Piston Housing	303 ss	1
11	12371		Piston Housing Seal	Nitrile	1
12	11753	11753	Piston Housing Screw	18-8 ss	3
13	24658		Lubricant Seal Back-Up	Acetal	1
13		24713	Lubricant Seal Back-Up	303 ss	1
14	12947		Lubricant Seal	Lubrithane	1
14		12991	Lubricant Seal	Fluorocarbon	1
15	10278	10278	Pipe Plug	304 ss	1
16	31808	31810	Bellows Adapter	303 ss	1
17	31807	31809	Bellows Housing	303 ss	1
18	24751	24751	Discharge Check Valve Assembly	316 ss	See Parts (figure 3)
19	25347	25348	Teflon Bellows Assembly	Teflon	1
20	11541	11542	Bellows Return Spring	302 ss	1
21	22879	22879	Suction Check Valve Assembly	316 ss	See Parts (figure 4)
22	20460	20460	Bleed Screw w/Hose Barb	316 ss	1
23	10996	11546	Bellows O-Ring	Fluorocarbon	1
24	12948	12960	Plunger Seal	Lubrithane	2
25	13275		Bellows Assembly Cap Screws	18.8 ss	5
25		13275	Bellows Assembly Cap Screws	18.8 ss	8
26	12300		Bellows Assembly Lock Washer	18.8 ss	5
26		12300	Bellows Assembly Lock Washer	18.8 ss	8
27	11390	11390	Upper Section Set Screw	18-8 ss	4
28	43738	44818	Center Housing	303 ss	1
29	13353	13354	O-Ring (Included in Assembly Item#19)	TFE Encap.	1

# METERING PUMPS

## P N E U M A T I C B E L L O W S

Figure 2, "T" Series Timer

Reference fig. 1, item1

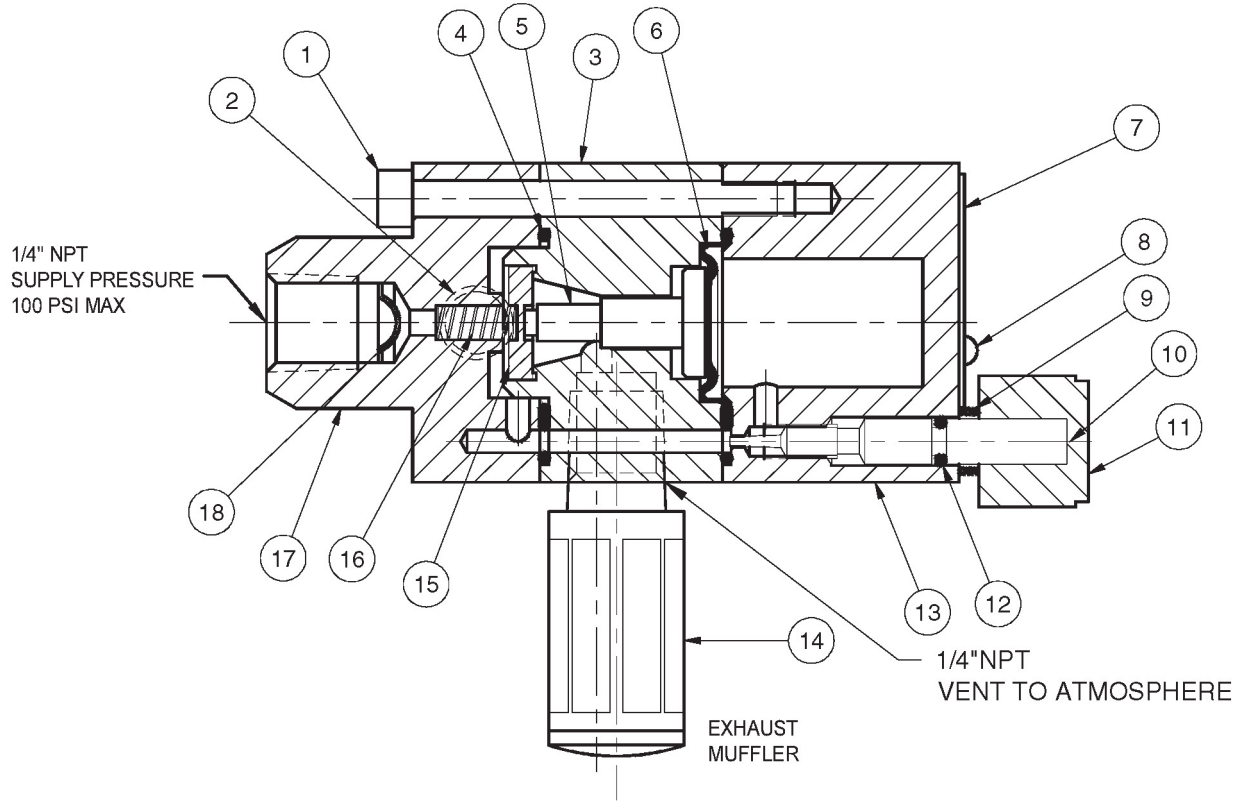

Assembly Item	Part #	Description	Material	Qty
1	13223	Screw	18-8 ss	2
2	25130	Hex Nipple	303 ss	1
3	31664	Center Body	303 ss	1
4	13227	Seal	Nitrile	1
5	13247	Disc Actuator	Delrin	1
6 *	13226	Diaphragm	Nitrile	1
7	13246	Nameplate	18-8 ss	1
8	10324	Drive Screw	18-8 ss	2
9	13253	Knob Spring	Stainless Steel	1
10	25149	Adjustment Screw	303 ss	1
11	13243	Knob	Polycarbon	1
12	10326	O-Ring	Nitrile	1
13 *	31663	Front Body	303 ss	1
14	12952	Muffler	Plastic	1
15	13225	Disc	Aluminum/Nitrile	1
16 *	13222	Disc Spring	Stainless steel	1
17	31665	Rear Body	303 ss	1
18 *	10244	Screen	Stainless Steel	1
*	25183	Repair Kit		1

# METERING PUMPS

## P N E U M A T I C B E L L O W S

Figure 3, Discharge Check Valve

Reference fig. 1, item 18

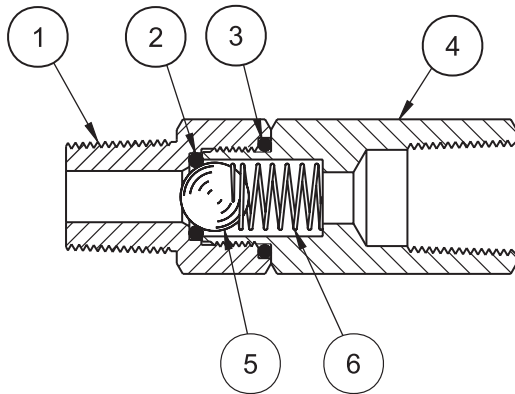

P/N 24751

Figure 4, Suction Check Valve

Reference fig. 1, item 21

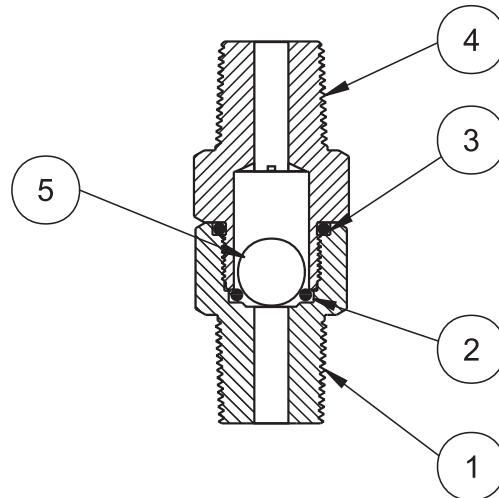

P/N 22879

Assembly	24751	Discharge Check Valve - Two Piece Body		Port Size: 1/4" NPTF
Item	Part #	Description	Material	Qty
1	23257	Inlet Body	316 ss	1
2	10313	Seat	TFE	1
3	11485	Seal	Fluorocarbon	1
4	24755	Outlet Body	316 ss	1
5	13276	Ball	Carbide	1
6	11438	Spring	316 ss	1

Assembly	22879	Suction Check Valve - Two Piece Body		Port Size: 1/4" NPTM
Item	Part #	Description	Material	Qty
1	23257	Inlet Body	316 ss	1
2	10313	Seat	TFE	1
3	11485	Seal	Fluorocarbon	1
4	23256	Outlet Body	316 ss	1
5	13276	Ball	Carbide	1

# METERING PUMPS

## LINC Chemical Pump Gas Consumption Table

ACTUATION PISTON DIA. (IN)>>	1.50	2.25	3	4	4	4	6	8	10
>> CONFIGURATION >>	SPRING RETURN NO RELAY	SPRING RETURN NO RELAY	SPRING RETURN NO RELAY	SPRING RETURN NO RELAY	SPRING RETURN INCLUDING RELAY	GAS RETURN INCLUDING RELAY	GAS RETURN INCLUDING RELAY	GAS RETURN INCLUDING RELAY	GAS RETURN INCLUDING RELAY
SUPPLY PRESS. (PSI)	VOLUME DISPLACED BY PISTON FOR 1" STROKE(CUBIC FEET)								
	0.00102265	0.00230097	0.00409062	0.00727221	0.00727221	0.01454441	0.03272492	0.05817764	0.09090257
	THEORETICAL GAS CONSUMPTION FOR EACH 1" STROKE (SCF)								
0	0.0000	0.0000	0.0000	0.0000	0.0000	0.0000	0.0000	0.0000	0.0000
10	0.0017	0.0039	0.0069	0.0122	0.0122	0.0244	0.0550	0.0978	0.1527
20	0.0024	0.0054	0.0097	0.0172	0.0172	0.0343	0.0772	0.1373	0.2146
30	0.0031	0.0070	0.0124	0.0221	0.0221	0.0442	0.0995	0.1769	0.2764
40	0.0038	0.0086	0.0152	0.0271	0.0271	0.0541	0.1218	0.2165	0.3383
50	0.0045	0.0101	0.0180	0.0320	0.0320	0.0640	0.1440	0.2561	0.4001
60	0.0052	0.0117	0.0208	0.0370	0.0370	0.0739	0.1663	0.2956	0.4619
70	0.0059	0.0133	0.0236	0.0419	0.0419	0.0838	0.1886	0.3352	0.5238
80	0.0066	0.0148	0.0264	0.0468	0.0468	0.0937	0.2108	0.3748	0.5856
90	0.0073	0.0164	0.0291	0.0518	0.0518	0.1036	0.2331	0.4144	0.6474
100	0.0080	0.0180	0.0319	0.0567	0.0567	0.1135	0.2553	0.4539	0.7093
110	0.0087	0.0195	0.0347	0.0617	0.0617	0.1234	0.2776	0.4935	0.7711
120	0.0094	0.0211	0.0375	0.0666	0.0666	0.1333	0.2999	0.5331	0.8330
130	0.0101	0.0226	0.0403	0.0716	0.0716	0.1432	0.3221	0.5727	0.8948
140	0.0108	0.0242	0.0430	0.0765	0.0765	0.1531	0.3444	0.6123	0.9566
150	0.0115	0.0258	0.0458	0.0815	0.0815	0.1630	0.3667	0.6518	1.0185







LINC Milton Roy represents and warrants that for a period of 3 years from receipt of the product: (1) the product will be free from defects in materials and workmanship; and (2) the product will perform substantially in accordance with product manuals, literature, or documentation. Any written or oral information or advice given by LINC Milton Roy representatives, agents, or employees will in no way increase the scope of this warranty. If the product fails to comply with the warranty set forth herein, LINC Milton Roy's entire liability and the customer's exclusive remedy will be replacement of the product(s) or, at LINC Milton Roy's option, LINC Milton Roy's reasonable effort to make the product meet the warranty set forth herein. **LINC Milton Roy disclaims all other warranties, either expressed or implied, including but not limited to, implied warranties or merchantability and fitness for a particular purpose, with respect to the product.** This limited warranty gives you specific legal rights. You may have others, which vary from state to state. **These remedies are not available outside of the United States and Canada.** In no event shall LINC Milton Roy or its suppliers be liable for any damages whatsoever (including, without limitation, damages for loss of profits, business interruption, loss of information, or other pecuniary loss) arising out of the use of or inability to use the product, even if LINC Milton Roy has been advised of the possibility of such damages. Information contained in this document is subject to change without notice and does not represent a commitment on the part of LINC Milton Roy. All prices quoted are in U.S. dollars, F.O.B. Ivyland, PA. LINC, LINC Chemical Pumps, and LINC Level & Flow Switches are trademarks of LINC Milton Roy. All other product names and/or registered trademarks are the property of their respective holders. LINC Milton Roy support services are subject to LINC Milton Roy's then-current prices, terms, and conditions, which are subject to change without notice. All prices and specifications, if published, are subject to change without notice.